

FFGROUP[®]

QUALITY POWER TOOLS

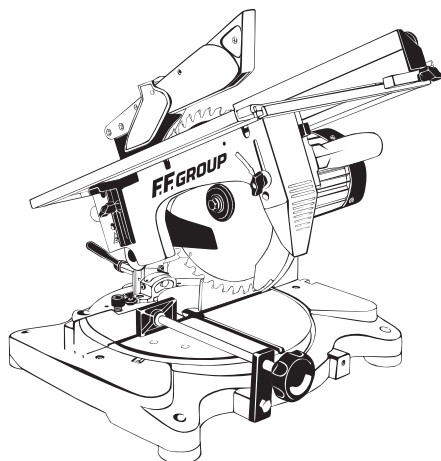

45 953 - TTMS 254 PLUS

45 954 - TTMS 254i PLUS

IT

MANUALE D'USO

EN

USER MANUAL

FR

MANUEL D'UTILISATION

BG

РЪКОВОДСТВО ЗА УПОТРЕБА

HR

PRIRUČNIK ZA UPORABU

SR

PRIRUČNIK ZA KORIŠĆENJE

EL

ΕΓΧΕΙΡΙΔΙΟ ΧΡΗΣΗΣ

RO

MANUAL DE INSTRUCȚIUNI

HU

FELHASZNÁLÓI KÉZIKÖNYV

- IT MANUALE D'USO
- EN USER MANUAL
- FR MANUEL D'UTILISATION
- BG РЪКОВОДСТВО ЗА УПОТРЕБА
- HR PRIRUČNIK ZA UPORABU
- SR PRIRUČNIK ZA KORIŠĆENJE
- EL ΕΓΧΕΙΡΙΔΙΟ ΧΡΗΣΗΣ
- RO MANUAL DE INSTRUCȚIUNI
- HU FELHASZNÁLÓI KÉZIKÖNYV

- IT **Istruzioni originali**
(conservare per usi futuri)
- EN **Translation of the original instructions**
(please retain for future reference)
- FR **Traduction des instructions originales**
(conserver pour tout usage futur)
- BG **Превод на оригиналните инструкции**
(съхранете за бъдеща употреба)
- HR **Prijevod originalnih uputa**
(čuvajte za buduću uporabu)
- SR **Prevod originalnih uputstava**
(sačuvajte za buduću upotrebu)
- EL **Μετάφραση των πρωτότυπων οδηγιών**
(διατηρηστε για μελλοντική χρήση)
- RO **Traducerea instrucțiunilor originale**
(a se conserva pentru a fi utilizate în viitor)
- HU **Eredeti utasítás fordítása**
(őrizze meg egy későbbi felhasználáshoz)



IT Per tutte le **NOTE DI AVVERTENZA** fare riferimento al documento "**NORME DI SICUREZZA GENERALI** allegato.

EN For all **WARNING NOTES** please refer to the attached "**GENERAL SAFETY REGULATIONS**" document

FR Pour toutes les **NOTES D'AVERTISSEMENT** se reporter au document « **NORMES GÉNÉRALES DE SÉCURITÉ** » en annexe.

BG За всички **ПРЕДУПРЕЖДЕНИЯ** направете справка с приложения документ "**ОБЩИ ПРАВИЛА ЗА БЕЗОПАСНОСТ**".







HR Za sva **UPOZORENJA** pogledajte prilog "**OPĆE SIGURNOSNE ODREDBE**".



SR Za sva **UPOZORENJA** pogledajte priloženi dokument "**OPŠTE BEZBEDNOSNE ODREDBE**".







EL Για όλες τις **ΣΗΜΕΙΩΣΕΙΣ ΠΡΟΕΙΔΟΠΟΙΗΣΕΩΝ** ανατρέξτε στο συνημμένο έγγραφο «**ΓΕΝΙΚΟΙ ΚΑΝΟΝΕΣ ΑΣΦΑΛΕΙΑΣ**».

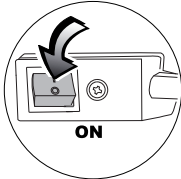
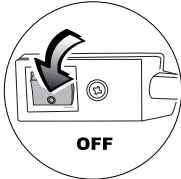
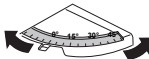

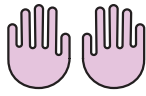

RO Pentru toate **NOTELE DE AVERTIZARE** consultați documentul "**NORME DE SIGURANȚĂ GENERALE** anexat.

HU Minden **FIGYELMEZTETÉS** esetében hivatkozni kell a csatolt „**ÁLTALÁNOS BIZTONSÁGI FELTÉTELEK**” című dokumentumra.

	<p> IT PERICOLO-ATTENZIONE! EN DANGER-WARNING! FR DANGER-ATTENTION! BG ОПАСНОСТ-ВНИМАНИЕ! HR OPASNOST-POZOR! SR OPASNOST-PAŽNJA! EL ΚΙΝΔΥΝΟΣ-ΠΡΟΣΟΧΗ! RO PERICOL-ATENȚIE! HU FIGYELEM! VESZÉLY! </p>
	<p> IT Nota EN Note FR Remarque BG Забележка HR Napomena SR Napomena EL Σημείωση RO Notă HU Megjegyzés </p>
	<p> IT DIVIETO EN PROHIBITION FR INTERDICTION BG ЗАБРАНАЕ HR ZABRANA SR ZABRANA EL ΑΠΑΓΟΡΕΥΣΗ RO INTERZIS HU TILOS </p>
	<p> IT Divieto di utilizzo guanti da lavoro EN Use of work gloves is prohibited FR Interdiction d'utiliser des gants de travail BG Забрана за употреба на работни ръкавици HR Zabrana uporabe radnih rukavica SR Zabrana korišćenja radnih rukavica EL Απαγόρευση της χρήσης γαντιών προστασίας RO Interzicerea utilizării mănușilor de muncă HU Munkakesztyű használata tilos </p>
	<p> IT Corretto EN Correct FR Correct BG Правилно HR Točno SR Tačno EL Σωστό RO Corect HU Helyes </p>
	<p> IT NON corretto EN NOT correct FR NON correct BG НЕправилно HR NE točno SR NE tačno EL ΜΗ σωστό RO INCORECT HU NEM helyes </p>
	<p> IT Prima di procedere leggere il foglio "NORME DI SICUREZZA GENERALI" EN Before proceeding, please read the "GENERAL SAFETY REGULATIONS" sheet FR Avant de procéder lire la notice «NORMES GÉNÉRALES DE SÉCURITÉ» BG Преди работа, прочетете листа "ОБЩИ ПРАВИЛА ЗА БЕЗОПАСНОСТ" HR Prije svega pročitajte poglavlje "OPĆE SIGURNOSNE ODREDBE" SR Pre svega pročitajte poglavlje "OPŠTE BEZBEDNOSNE ODREDBE" EL Πριν συνεχίσετε διαβάστε το δελτίο «ΓΕΝΙΚΟΙ ΚΑΝΟΝΕΣ ΑΣΦΑΛΕΙΑΣ» RO Înainte de a continua, citiți fișa „NORME DE SIGURANȚĂ GENERALE” HU Mielőtt továbblépné, olvassa el az "ÁLTALÁNOS BIZTONSÁGI FELTÉTELEK" című dokumentumot </p>

	<ul style="list-style-type: none"> IT Leggere la pagina identificata dal simbolo EN Read the page identified by the symbol FR Lire la page identifiée par le symbole BG Прочетете страницата, идентифицирана със символа HR Pročitajte stranicu označenu simbolom SR Pročitajte stranu označenu simbolom EL Διαβάστε τη σελίδα που προσδιορίζεται από το σύμβολο RO Citiți pagina identificată cu simbolul HU Olvassa el a szimbóllummal ellátott oldalt
	<ul style="list-style-type: none"> IT Misure e distanze da rispettare EN Measurements and distances to be observed FR Mesures et distances à respecter BG Размери и разстояния, които да се спазват HR Mjere i razdaljine koje trebate poštivati SR Mere i razdaljine koje moraju da se poštuju EL Μεγέθη και αποστάσεις προς τήρηση RO Măsuri și distanțe ce trebuie respectate HU Betartandó mértékek és távolságok
 <p style="text-align: center;">ON</p>	<ul style="list-style-type: none"> IT ACCENDERE la macchina EN SWITCH ON the machine MASCHINE einschalten FR DÉMARRER la machine BG ВКЛЮЧЕТЕ машината HR UKLJUČITI stroj SR UKLJUČITE mašinu EL ΕΝΕΡΓΟΠΟΙΗΣΤΕ τη μηχανή RO PORNIȚI mașina HU A GÉP bekapcsolása
 <p style="text-align: center;">OFF</p>	<ul style="list-style-type: none"> IT SPEGNERE la macchina EN SWITCH OFF the machine FR METTRE LA MACHINE hors tension BG ИЗКЛЮЧЕТЕ машината HR ISKLJUČITI stroj SR ISKLJUČITE mašinu EL ΑΠΕΝΕΡΓΟΠΟΙΗΣΤΕ τη μηχανή RO OPRIȚI mașina HU A GÉP kikapcsolása
	<ul style="list-style-type: none"> IT Angolo di taglio/rotazione testa EN Cutting angle/head rotation FR Angle de coupe/rotation de la tête BG Ъгъл на рязане/въртене на главата HR Kut rezanja/okretanje glave SR Ugao sečenja/obrtnanja glave EL Γωνία κοπής/περιστροφή κεφαλής RO Unghi de tăiere/rotire a capului HU Vágásszög/fej elfordításának szöge

	<p>IT Potenza EN Power FR Puissance BG Мощност HR Snaga SR Snaga EL Ισχύς RO Putere HU Teljesítmény</p>
	<p>IT Tensione/Frequenza EN Voltage/Frequency FR Tension/Fréquence BG Напряжение/Честота HR Napon/Frekvencija SR Napon/Frekvencija EL Τάση/Συχνότητα RO Tensiune/Frecvență HU Feszültség/Frekvencia</p>
	<p>IT REGOLAZIONI EN ADJUSTMENTS FR RÉGLAGES BG НАСТΡΟΪΚΙ HR NAMJEŠTANJA SR PODEŠAVANJA EL ΡΥΘΜΙΣΕΙΣ RO REGLAJE HU BEÁLLÍTÁSOK</p>
	<p>IT UTILIZZO EN USE FR UTILISATION BG УПОТРЕБА HR UPORABA SR UPOTREBA EL ΧΡΗΣΗ RO UTILIZARE HU HASZNÁLAT</p>
	<p>IT MANUTENZIONE EN MAINTENANCE FR ENTRETIEN BG ПОДДРЪЖКА HR ODRŽAVANJE SR ODRŽAVANJE EL ΣΥΝΤΗΡΗΣΗ RO ÎNTREȚINEREA HU KARBANTART</p>
	<p>IT Rumore EN Noise FR Bruit BG Шум HR Buka SR Buka EL Θόρυβος RO Zgomot HU Zaj</p>
	<p>IT Peso EN Weight FR Poids BG Тегло HR Težina SR Težina EL Βάρος RO Greutate HU Súly</p>
	<p>IT Operazione da eseguire con PRUDENZA EN Operation to be performed with CARE FR Opération à effectuer avec PRUDENCE BG Операция, която да се извършва с ПРЕДПАЗЛИВОСТ HR Vršite izvedbu ove radnje POZORNO SR Radnje koje morate da obavljate PAŽLJIVO EL Λειτουργία προς εκτέλεση με ΠΡΟΣΟΧΗ RO Operațiune ce trebuie efectuată cu PRUDENȚĂ HU Körültekintéssel végzendő MŰVELET</p>

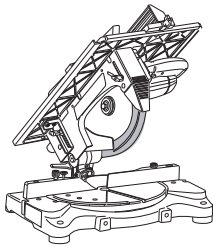
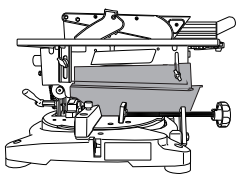
	<p> IT Operazione da eseguire con FORZA EN Operation to be performed with FORCE FR Opération à effectuer avec FORCE BG Операция, която да се извършва със СИЛА HR Vršite izvedbu ove radnje NASILNO SR Radnje koje morate da obavljate NASILNO EL Διαδικασία προς εκτέλεση με ΠΡΟΣΟΧΗ RO Operațiune ce trebuie efectuată cu FORȚĂ HU Erővel végzendő MŰVELET </p>
	<p> IT PULIZIA EN CLEANING FR NETTOYAGE BG ПОЧИСТВАНЕ HR ČIŠĆENJE SR ČIŠĆENJE EL ΚΑΘΑΡΙΣΜΟΣ RO CURĂȚARE HU TISZTÍTÁS </p>
	<p> IT VERIFICHE EN CHECKS FR VÉRIFICATIONS BG ПРОВЕРКИ HR PREGLED SR PROVERE EL ΕΛΕΓΧΟΙ RO VERIFICĂRI HU ELLENŐRZÉS </p>
	<p> IT Oggetto da RICICLARE EN Object to be RECYCLED FR Objet à RECYCLER BG Предмет за РЕЦИКЛИРАНЕ HR Predmet za RIKIKLAŽU SR Predmet koji morate da RECIKLIRATE EL Αντικείμενο προς ανακύκλωση RO Obiect de RECICLAT HU ÚJRAHASZNOSÍTANDÓ termék </p>
	<p> IT Modalità troncatrice EN Mitre saw mode FR Mode tronçonneuse BG Режим циркуляр HR Način rada preklopane pile SR Režim rezača EL Τρόπος λειτουργίας μηχανής κοπής RO Mod mașină de tăiat HU Gérvágó üzemmód </p>
	<p> IT Modalità sega da banco EN Bench saw mode FR Mode scie à banc BG Режим настолен циркуляр HR Način rada stolne pile SR Način rada stonog cirkulara EL Τρόπος λειτουργίας επιτραπέζιου πριονιού RO Mod fierăstrău de banc HU Asztali körfűrész üzemmód </p>

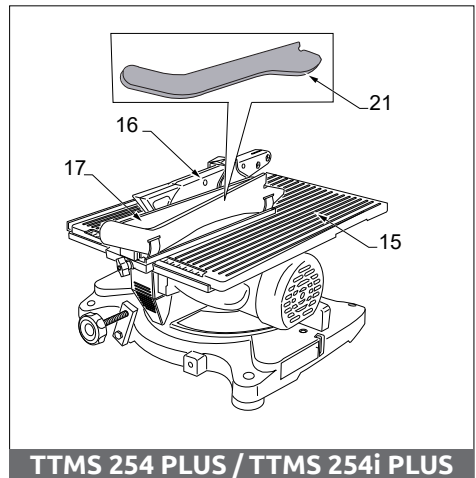
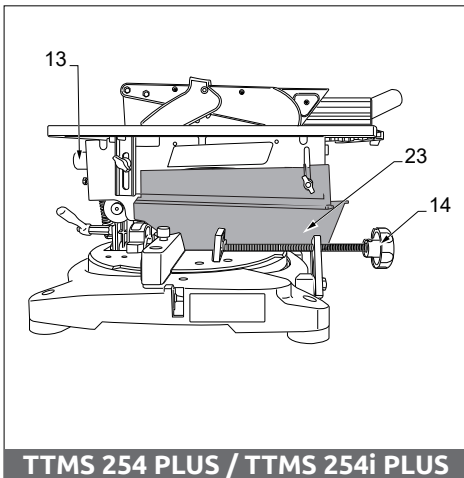
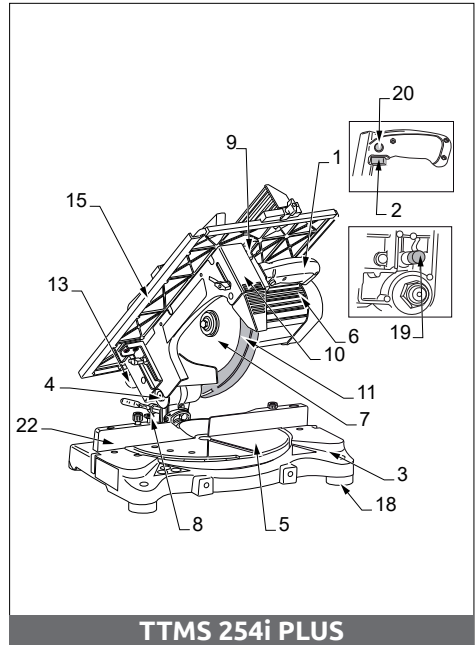
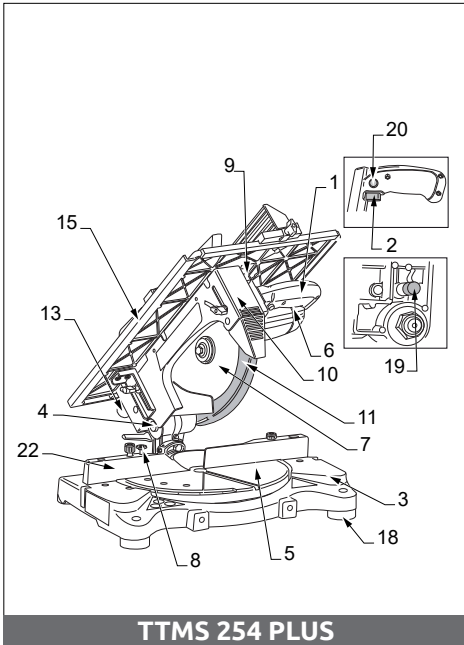

IT

1. Impugnatura di comando
2. Interruttore di marcia
3. Base
4. Snodo corpo/base
5. Supporto girevole
6. Motore
7. Lama
8. Leva sblocco graduazione
9. Pulsante di sblocco discesa corpo
10. Protezione fissa lama
11. Protezione mobile lama
12. Fermo barra (optional)
13. Collettore scarico polvere



14. Morsetto ferma pezzo
15. Piano di lavoro superiore
16. Protezione mobile superiore
17. Squadra di appoggio
18. Piedi di appoggio
19. Perno di blocco
20. Pulsante blocco interruttore
21. Spintore
22. Appoggio
23. Protezione inferiore
24. Sacchetto raccogli polvere (optional)
25. Manuale d'uso
26. Manuale "NORME DI SICUREZZA GENERALI"

EN

1. Control handgrip
2. Start switch
3. Base
4. Body/base swivel joint
5. Swivel support
6. Motor
7. Blade
8. Lever to unblock graduation-scale
9. Button to unblock body descent
10. Fixed blade guard
11. Moveable blade guard
12. Bar holder (optional)
13. Dust collection manifold



14. Workpiece holder clamp
15. Upper work surface
16. Upper moveable guard
17. Rest square
18. Support feet
19. Lock pin
20. Switch locking button
21. Pusher
22. Fence
23. Lower guard
24. Dust bag (optional)
25. User Manual
26. Manual "GENERAL SAFETY REGULATIONS"

FR

1. Poignée de commande
2. Interrupteur de mise en marche
3. Base
4. Articulation corps/base
5. Support tournant
6. Moteur
7. Lame
8. Levier de déblocage graduation
9. Bouton-poussoir de déblocage descente corps
10. Protection fixe de la lame
11. Protection mobile de la lame
12. Arrêt de la barre (en option)
13. Collecteur d'évacuation de la poussière



14. Étau de blocage de la pièce
15. Plan de travail supérieur
16. Protection mobile supérieure
17. Équerre d'appui
18. Pieds d'appui
19. Goujon de blocage
20. Bouton-poussoir de blocage interrupteur
21. Pousseur
22. Appui
23. Protection inférieure
24. Sac ramasse-poussière (en option)
25. Manuel d'utilisation
26. Manuel « NORMES GÉNÉRALES DE SÉCURITÉ »

BG

1. Контролна ръкохватка
2. Прекъсвач за пускане
3. Основа
4. Нит корпус/основа
5. Въртящ супорт
6. Двигател
7. Нож
8. Лост отблокиране степени
9. Бутон за отблокиране спускане корпус
10. Неподвижен защита нож
11. Подвижна защита
12. Стопер преграда (опция)
13. Контейнер за събиране на прах



14. Стоп клема парче
15. Горен работен плот
16. Горна подвижна защита
17. Основа за поставяне
18. Крачета за поставяне
19. Щифт за блокиране
20. Бутон блокиране прекъсвач
21. Бутало
22. Основа
23. Долна защита
24. Пакет за събиране пране (опция)
25. Ръководство за употреба
26. Ръководство „ОБЩИ ПРАВИЛА ЗА БЕЗОПАСНОСТ“

HR

1. Upravljačka ručka
2. Prekidač za pokretanje
3. Baza
4. Zajedničko tijelo/baza
5. Okretni nosač
6. Motor
7. Sječivo
8. Poluga za postupno deblokiranje
9. Gumb za deblokiranje spuštanja tijela
10. Fiksna zaštita sječiva
11. Mobilna zaštita sječiva
12. Zaustavljač šipke (izborno)
13. Kolektor ispušne prašine



14. Terminal za zaustavljanje komada
15. Viša radna ploča
16. Gornja mobilna zaštita
17. Potporni kut
18. Potporne noge
19. Zaporni klin
20. Gumb za blokiranje prekidača
21. Potiskivač
22. Podrška
23. Donja zaštita
24. Vrećica za prašinu (izborno)
25. Priručnik za uporabu
26. Priručnik „OPĆE SIGURNOSNE MJERE“

SR

1. Kontrolna ručka
2. Prekidač za pokretanje
3. Osnova
4. Zglob za telo/osnovu
5. Obrtno postolje
6. Motor
7. Sečivo
8. Poluga za debokiranje deljenja na stepenove
9. Prekidač za deblokiranje spuštanja tela
10. Fiksna zaštita sečiva
11. Mobilna zaštita sečiva
12. Zaustavljanje poluge (optional)
13. Izduvni kolektor prašine



14. Stezaljka za zaustavljanje komada
15. Gornja radna površina
16. Gornja mobilna zaštita
17. Grupa za oslonac
18. Podupirajuće noge
19. Osovina poluge za blokiranje
20. Dugme za blokiranje prekidača
21. Gurač
22. Oslonac
23. Donja zaštita
24. Vrećica za skupljanje prašine (optional)
25. Priručnik za korišćenje
26. Priručnik "OPŠTA SIGURNOSNA PRAVILA"

EL



1. Λαβή χειρισμού
2. Διακόπτης πορείας
3. Βάση
4. Άρθρωση σώματος/βάσης
5. Περιστρεφόμενο στήριγμα
6. Κινητήρας
7. Λεπίδα
8. Μοχλός απεμπλοκής διαβάθμισης
9. Κουμπί απεμπλοκής καθόδου σώματος
10. Σταθερή προστασία λεπίδας
11. Προστασία κινητής λεπίδας
12. Αναστολέας γραμμής (προαιρετικά)
13. Συλλέκτης εκκένωσης σκόνης

14. Σύνδεσμος αναστολής τεμαχίου
15. Άνω επιφάνεια εργασίας
16. Άνω κινητή προστασία
17. Σύστημα στήριξης
18. Ποδαράκια στήριξης
19. Πείρος εμπλοκής
20. Κουμπί εμπλοκής διακόπτη
21. Προωθητήρας
22. Στήριγμα
23. Σακουλάκι συλλογής σκόνης (προαιρετικά)
24. Εγχειρίδιο χρήσης
25. Εγχειρίδιο "ΓΕΝΙΚΟΙ ΚΑΝΟΝΙΣΜΟΙ ΑΣΦΑΛΕΙΑΣ"

RO



1. Măner de comandă
2. Întrerupător de pornire
3. Bază
4. Articulație corp/bază
5. Suport rotativ
6. Motor
7. Lamă
8. Manetă deblocare treptată
9. Buton de deblocare coborâre corp
10. Protecție fixă lamă
11. Protecție mobilă lamă
12. Opritor bară (facultativ)
13. Colector evacuare praf
14. Terminal oprire piesă

15. Plan de lucru superior
16. Plan mobil superior
17. Etrier de sprijin
18. Picioare de sprijin
19. Pivotal de blocare
20. Buton blocare întrerupător
21. Dispozitiv de împingere a piesei
22. Suprafață de sprijin
23. Protecție inferioară
24. Sac colectare praf (facultativ)
25. Manual de instrucțiuni
26. Manual „NORME DE SIGURANȚĂ GENERALE”

HU



1. Vezérlő fogantyú
2. Menetmegszakító
3. Bak
4. Bak/géptest csukló
5. Elfordítható tartó
6. Motor
7. Fűrészlap
8. Gérvágási szög kioldókar
9. Géptest leeresztése kioldógomb
10. Fűrészlap rögzített védőburkolata
11. Fűrészlap mozgó védőburkolata
12. Rúdrögzítő (opcionális)
13. Porelvezető gyűjtőcső
14. Munkadarab-rögzítő satu

15. Felső munkasztal
16. Felső mozgó védőburkolat
17. Derékszög vezető
18. Lábak
19. Rögzítőcsap
20. Kapcsoló biztonsági reteszelőgombja
21. Toló
22. Támogatás
23. Alsó védőburkolat
24. Porzsák (opcionális)
25. Felhasználói kézikönyv
26. „ÁLTALÁNOS BIZTONSÁGI ELŐÍRÁSOK” kézikönyv

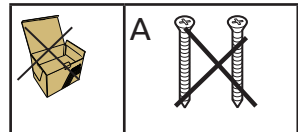
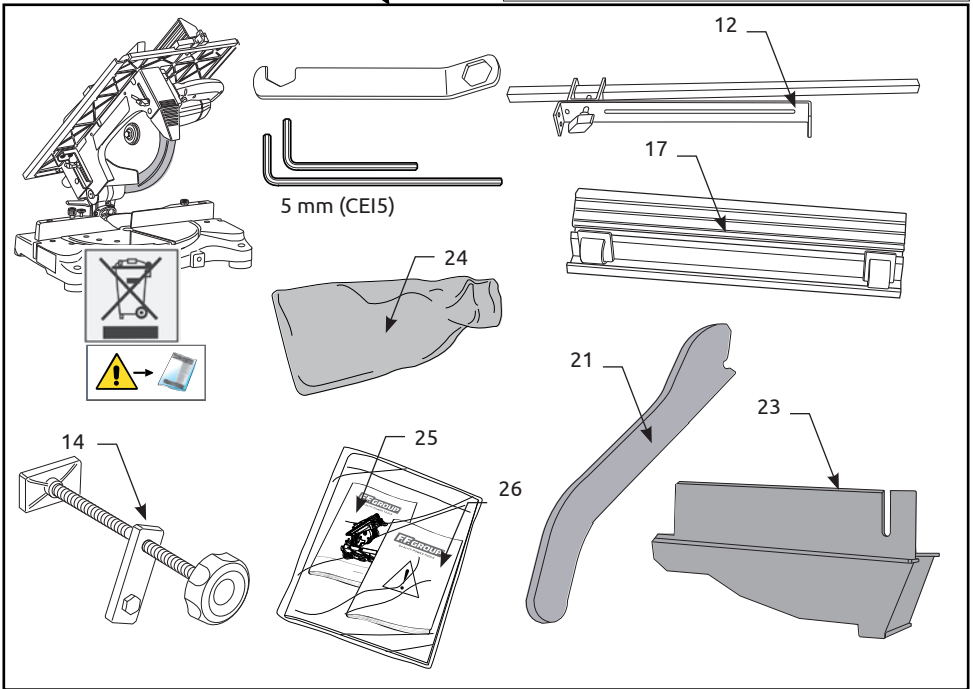
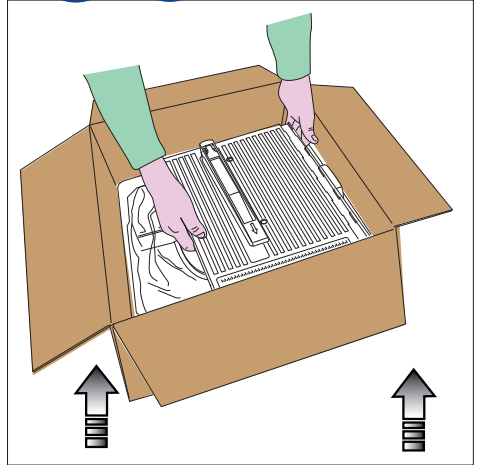
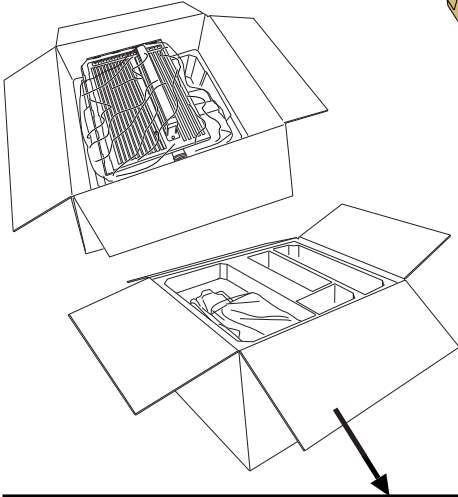

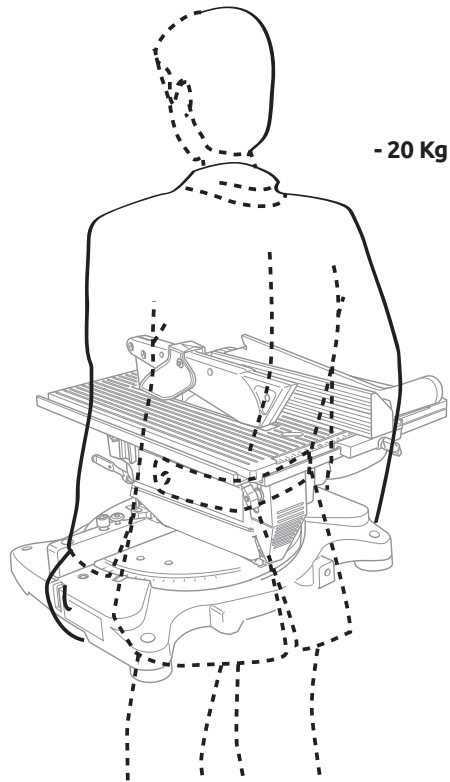
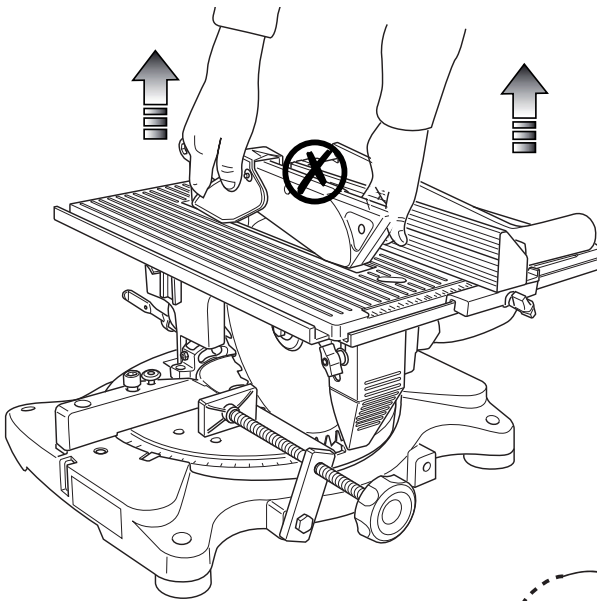



- IT** Indicazione caratteristiche e dati motore S4-20% 5 min =
Servizio del motore intermittente periodico con avviamento, con un tempo di funzionamento a carico costante alla potenza indicata (1 min) e un tempo di riposo (4 min).
- EN** Indication of motor characteristics and motor data S4-20% 5 min =
Intermittent periodic duty-type with starting, time of operation at constant load at the power indicated (1 min) and a rest time (4 min).
- FR** Indication des caractéristiques et des données du moteur S4-20% 5 min =
Service intermittent périodique à démarrage du moteur, avec un temps de fonctionnement à charge constante, à la puissance indiquée à (1 min) et un temps de repos à (4 min).
- BG** Посочване на характеристиките и данни за двигателя S4-20% 5 min =
Периодична работа на двигател с прекъснато действие, с работно време при постоянно натоварване, при посочената мощност (1 минути) и с време на покой при (4 минути).
- HR** Značajke i podaci o motoru S4-20% 5 min =
Povremeno i periodično servisiranje motora s pokretanjem, vremenom rada pod stalnim opterećenjem uz snagu od (1 min) i vremenom prekida rada od (4 min).
- SR** Označavanje karakteristika i podaci o motoru S4-20% 5 min =
Servis motora sa iprekidanim periodičnim načinom rada sa pogonom, za vreme rada pod konstantnim opterećenjem naznačene snage (1 min) i vreme odmora (4 min).
- EL** Υπόδειξη χαρακτηριστικών και στοιχείων κινητήρα S4-20% 5 min =
Λειτουργία του κινητήρα με διαλείμματα, με χρόνο λειτουργίας σταθερού φορτίου στην ισχύ που υποδεικνύεται (1 min) και χρόνο ανάπαυσης (4 min).
- RO** Indicarea caracteristicilor și a datelor motorului S4-20% 5 min =
Funcționare motorului intermitentă, periodică, cu pornire, cu un timp de funcționare cu sarcină constantă la puterea indicată de (1 min.) și un timp de repaus de (4 min.).
- HU** S4-20% 5 min - motor jellemzői és adatai
Szakaszosan működöttethető motor indítással, a feltüntetett állandó terhelési teljesítmény mellett (1 perc) működési idővel és (4 perc) pihentetési idővel.



IT Indicazione caratteristiche e dati motore S6-40%=

Servizio del motore intermittente periodico con avviamento, con un tempo di funzionamento a carico costante alla potenza indicata (2 min) e un tempo a vuoto.(4 min).

EN Indication of motor characteristics and motor data S6-40% =

Intermittent periodic duty-type with starting, time of operation at constant load at the power indicated (2 min) and a time when empty (4 min).

FR Indication des caractéristiques et des données du moteur S6-40%=

Service intermittent périodique à démarrage du moteur, avec un temps de fonctionnement à charge constante, à la puissance indiquée à (2 min) et un temps à vide à (4 min).

BG Посочване на характеристиките и данни за двигателя S6-40%=

Периодична работа на двигател с прекъснато действие, с работно време при постоянно натоварване, при посочената мощност (2 минути) и вакуум от време (4 минути).

HR Značajke i podaci o motoru S6-40%=

Povremeno i periodično servisiranje motora s pokretanjem, vremenom rada pod stalnim opterećenjem uz snagu od (2 min) i vakuum vremena (4 min).

SR Označavanje karakteraistika i podaci o motoru S6-40%=

Servis motora sa iprekidanim periodičnim načinom rada sa pogonom, za vreme rada pod konstantnim opterećenjem naznačene snage (2 min) i vakuum vremena (4 min).

EL Υπόδειξη χαρακτηριστικών και στοιχείων κινητήρα S6-40%=

Λειτουργία του κινητήρα με διαλείμματα, με χρόνο λειτουργίας σταθερού φορτίου στην ισχύ που υποδεικνύεται (2 λεπτά) και ένα κενό διάστημα (4 λεπτά).

RO Indicarea caracteristicilor și a datelor motorului S6-40%=

Funcționare motorului intermitentă, periodică, cu pornire, cu un timp de funcționare cu sarcină constantă la puterea indicată de (2 min.) și un vid de timp (4 min.).

HU S4-20% 5 min - motor jellemzői és adatai

Szakaszosan működtethető motor indítással, a feltüntetett állandó terhelési teljesítmény mellett (2 perc) működési idővel és (4 perc) hogy üres idővel.

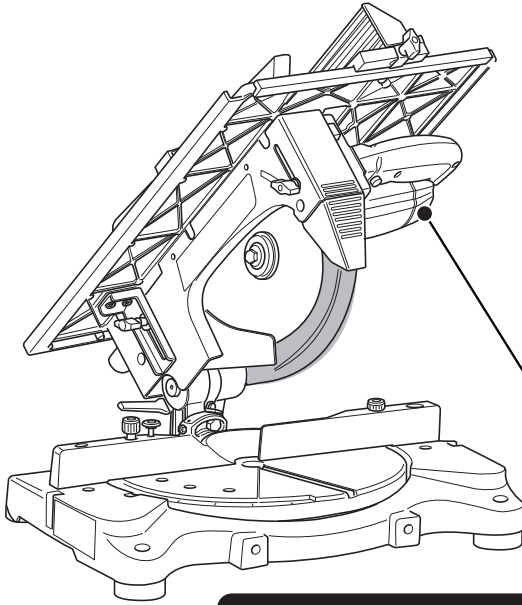

FF GROUP 

no: _____ kg

_____ W _____ A Is.c.l.F

FF GROUP TOOL INDUSTRIES Made in P.R.C.  

  

D max: _____
D min: _____

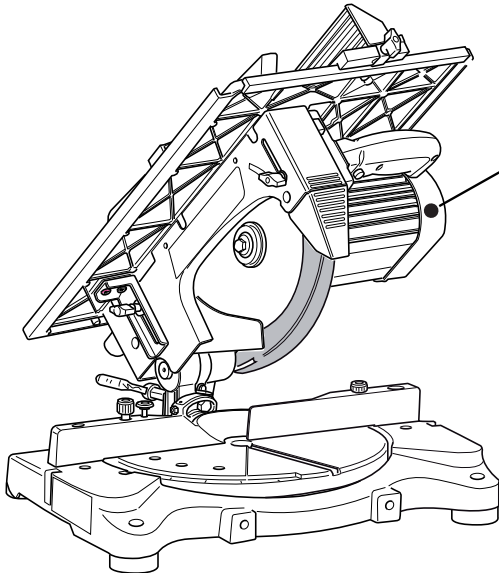



- IT Utilizzo dispositivi di protezione individuali
- EN Use personal protective equipment
- FR Utilisation de dispositifs de protection individuelle
- BG Използване на лични предпазни средства
- HR Uporaba osobne zaštitne opreme
- SR Korišćenje ličnih zaštitnih sredstava
- EL Χρήση μέσων ατομικής προστασίας
- RO Utilizarea echipamentelor de protecție individuală
- HU Egyéni biztonsági felszerelés használata

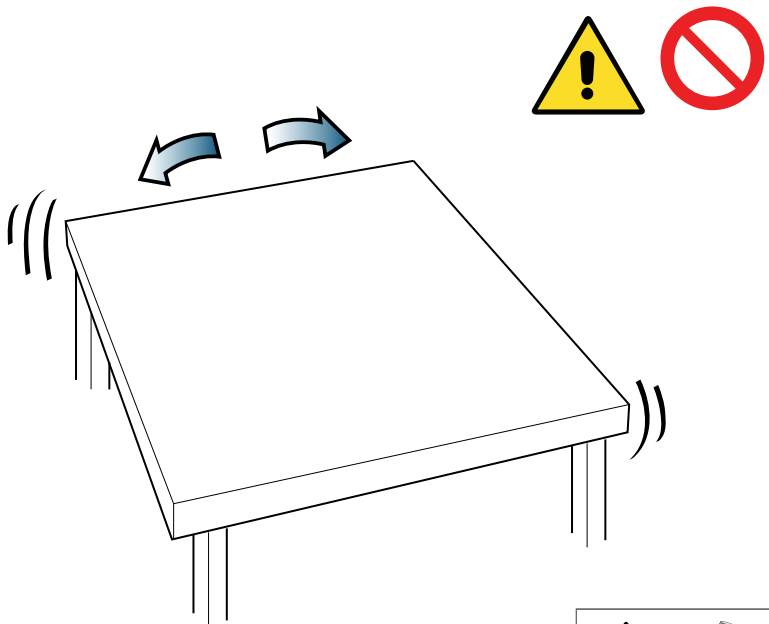
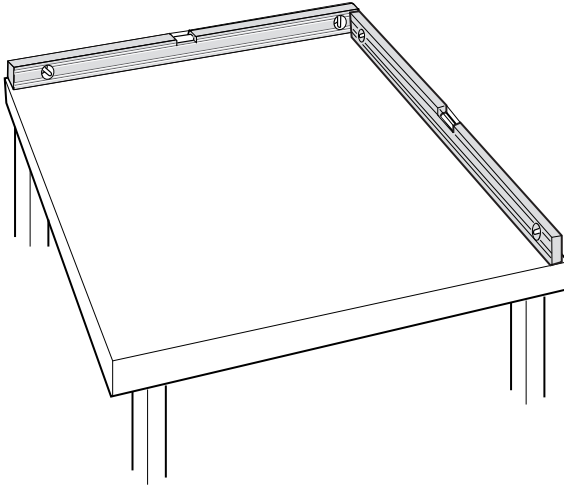

TTMS 254 PLUS / TTMS 254i PLUS

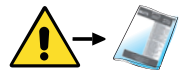
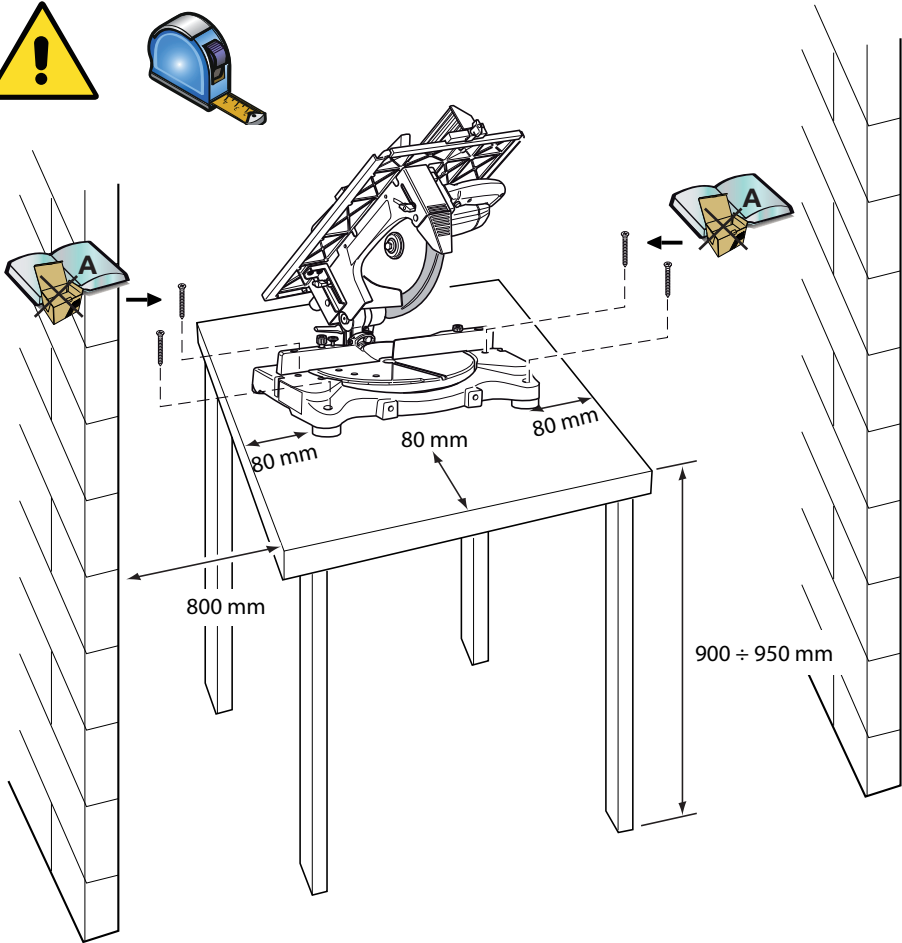

TTMS 254 PLUS / TTMS 254i PLUS

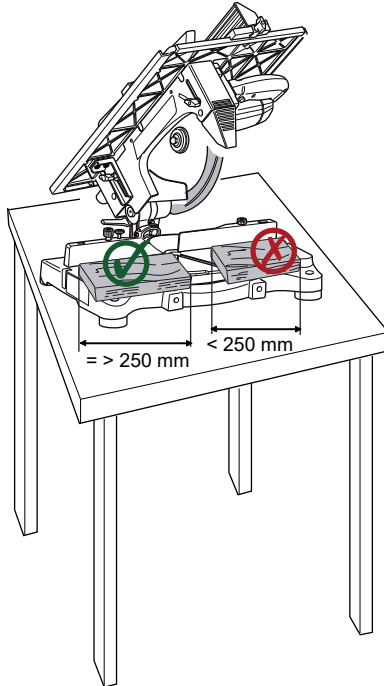
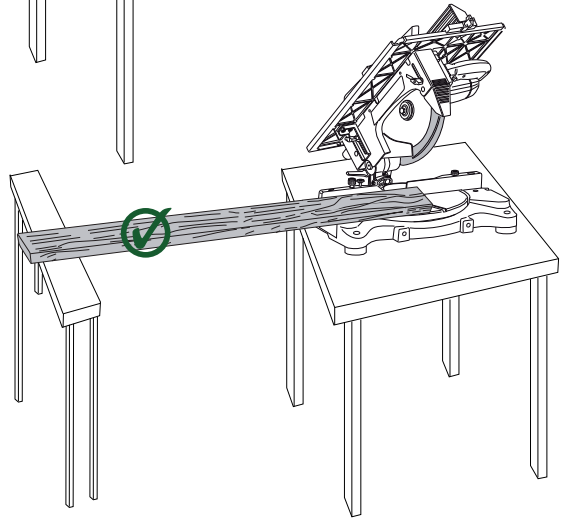
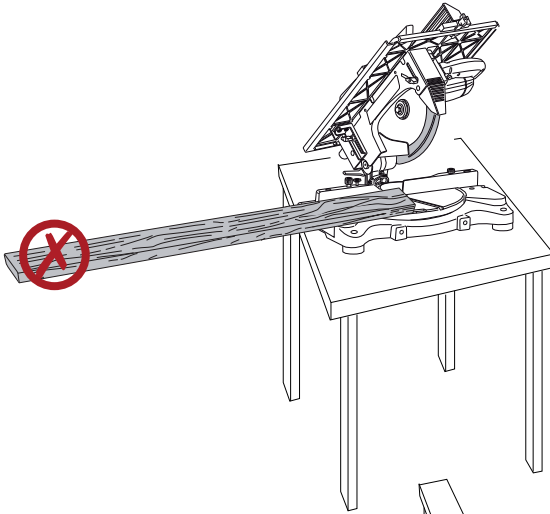

TTMS 254 PLUS / TTMS 254i PLUS

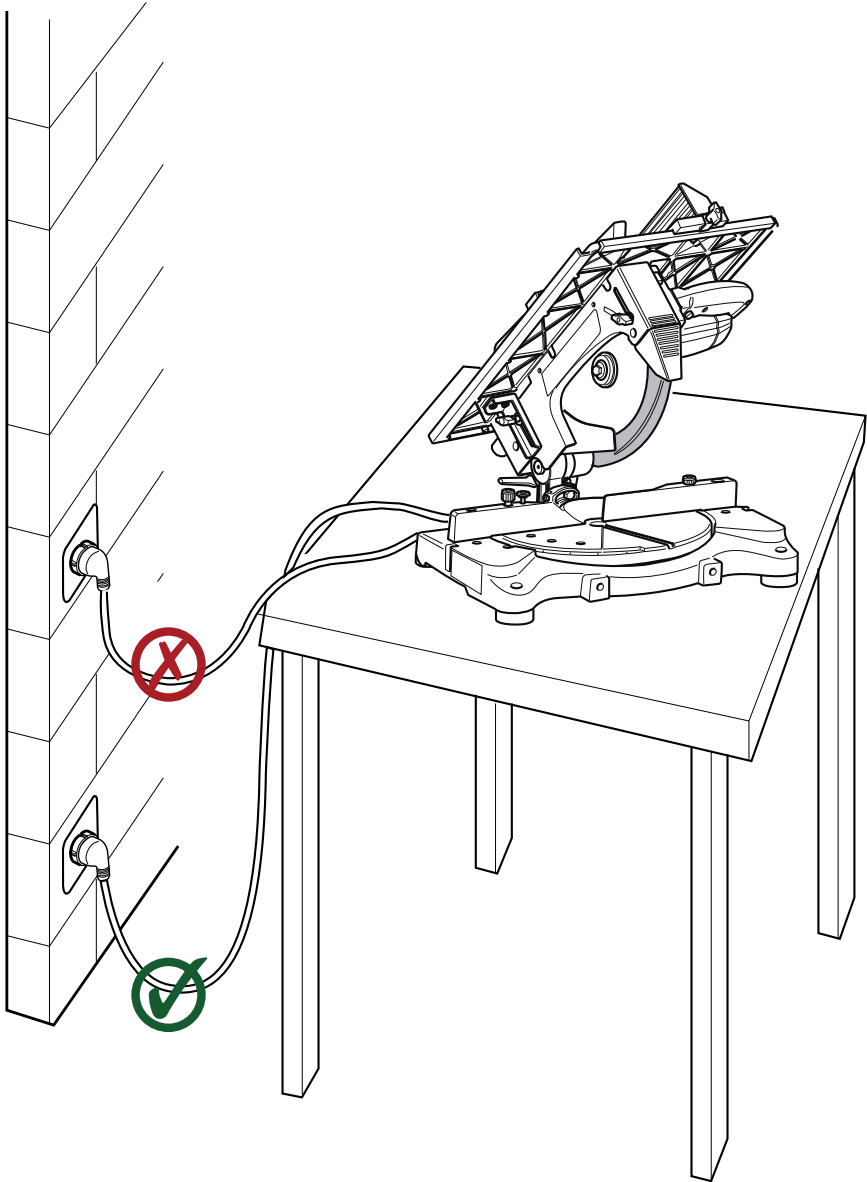

TTMS 254 PLUS / TTMS 254i PLUS

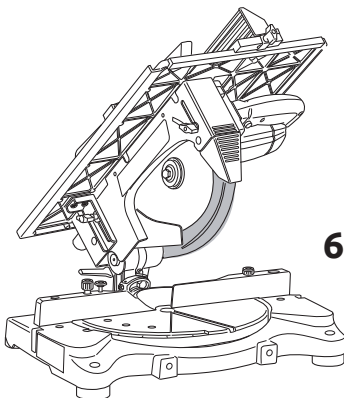
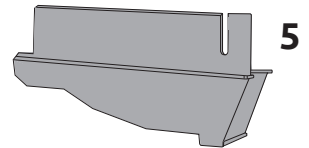
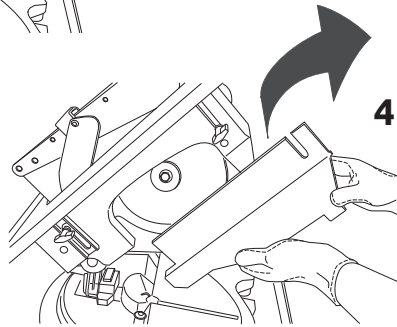
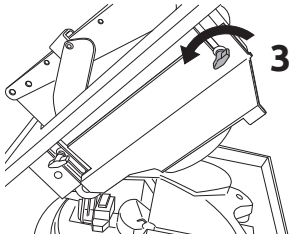
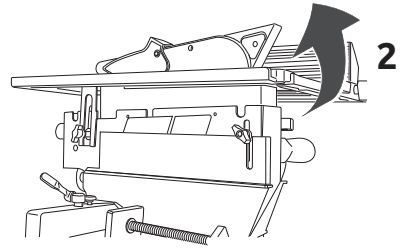
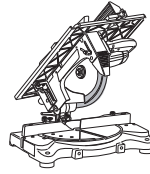
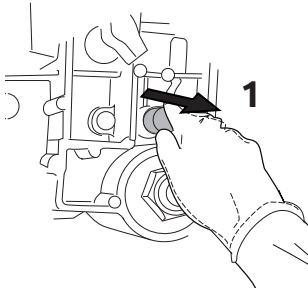

TTMS 254 PLUS / TTMS 254i PLUS

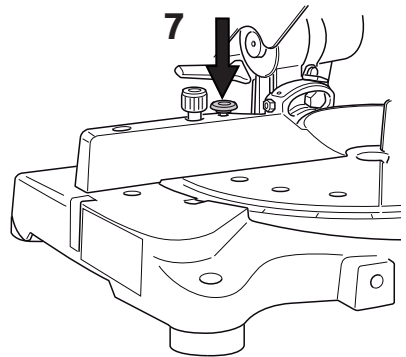
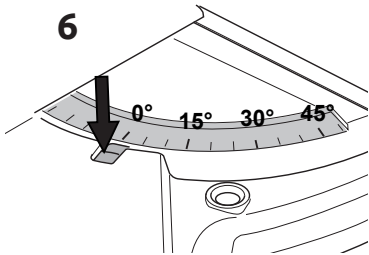
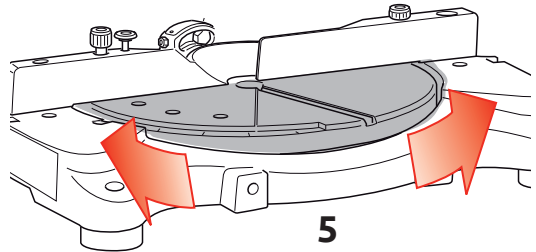
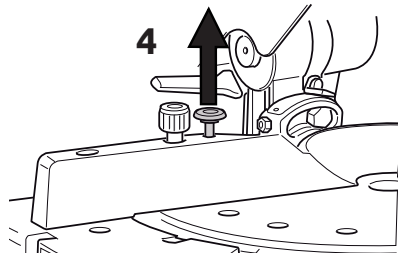
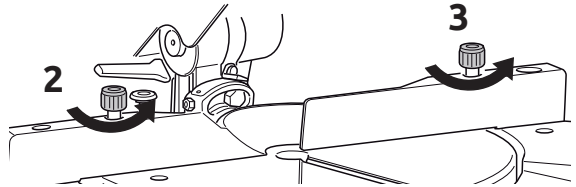
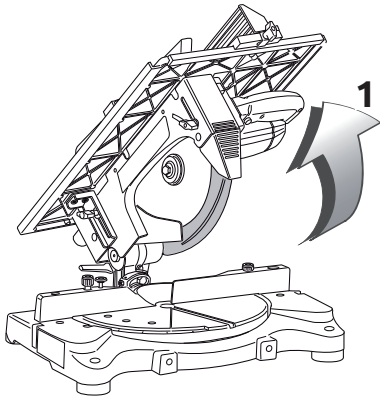
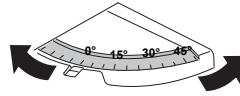

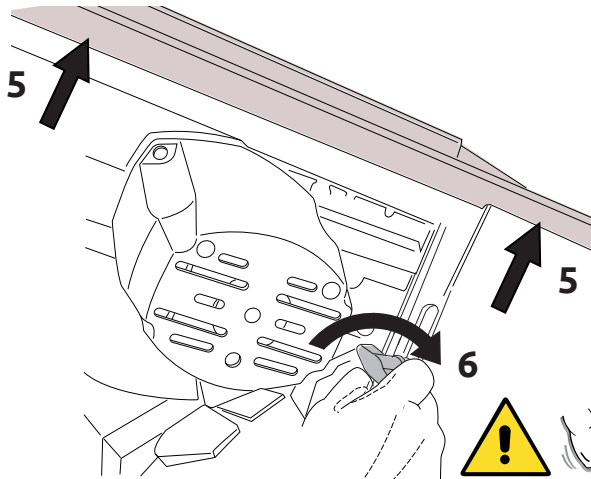
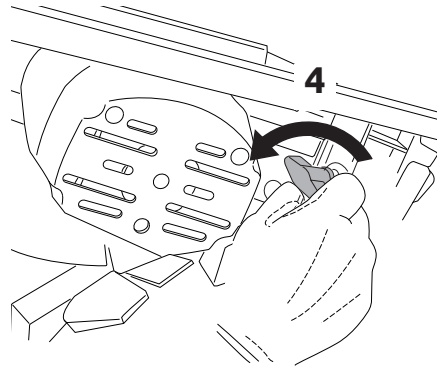
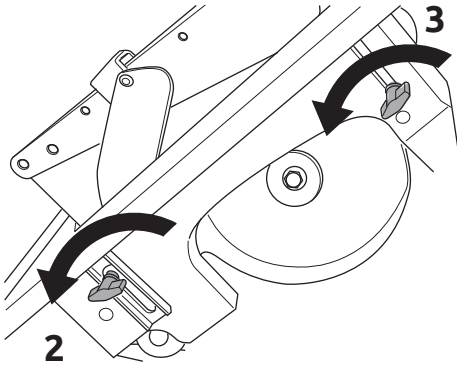
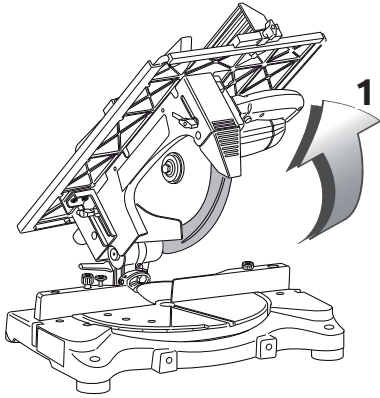

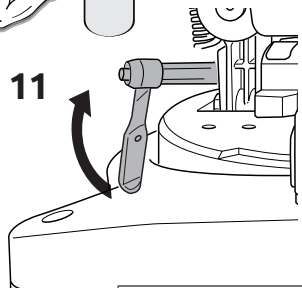
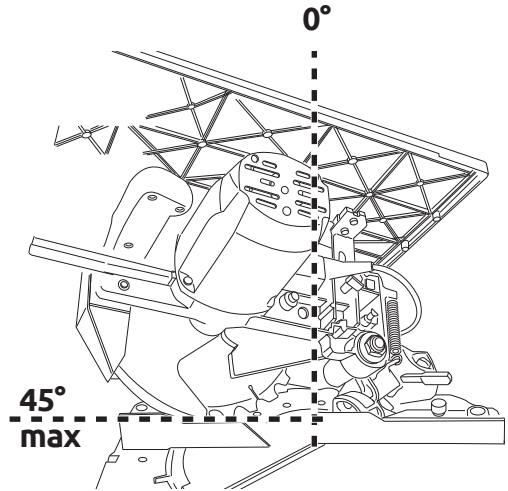
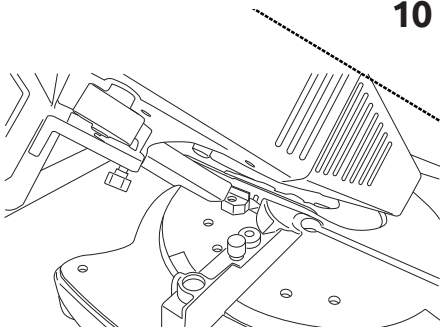
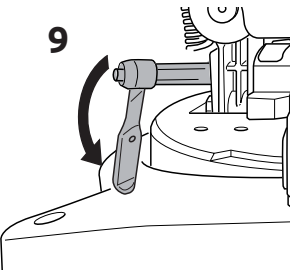
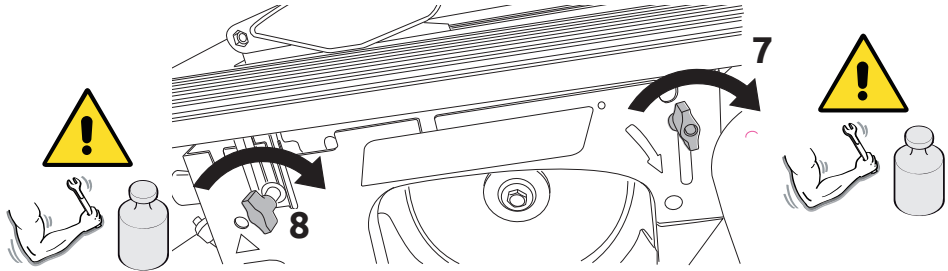

0° - 45°

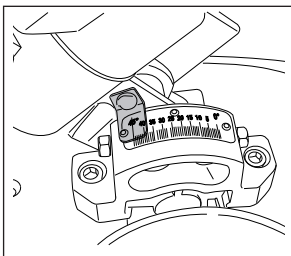

TTMS 254 PLUS / TTMS 254i PLUS

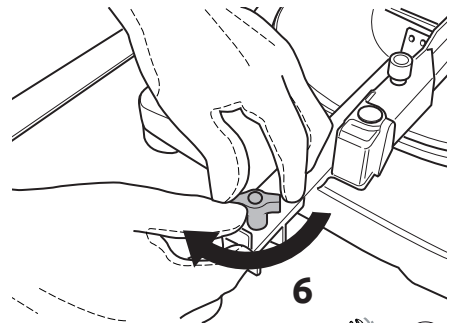
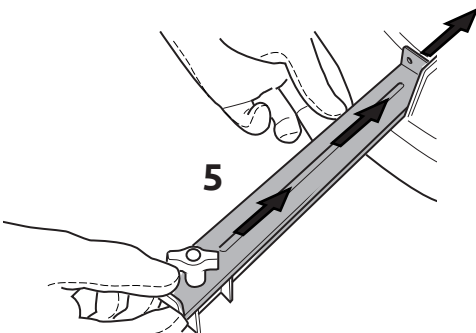
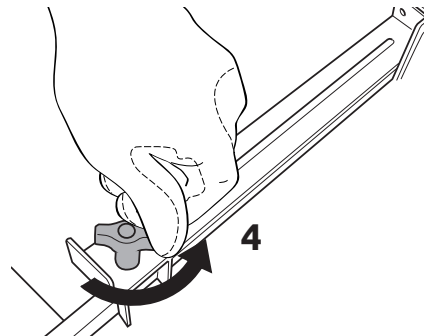
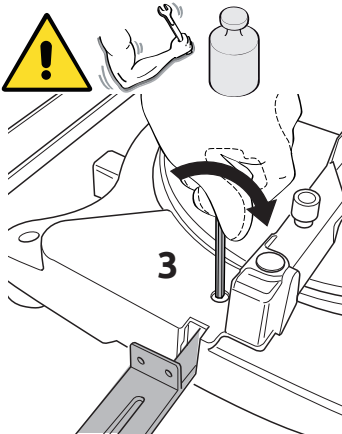
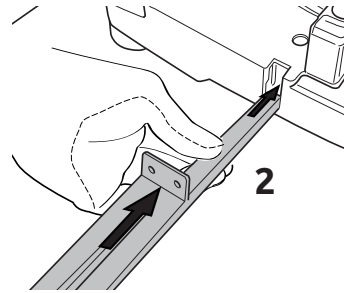
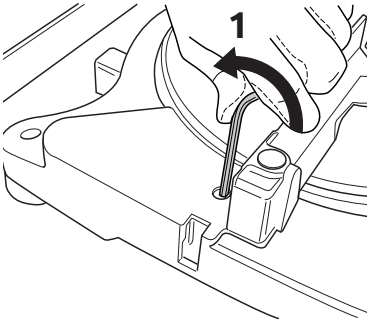

TTMS 254 PLUS / TTMS 254i PLUS

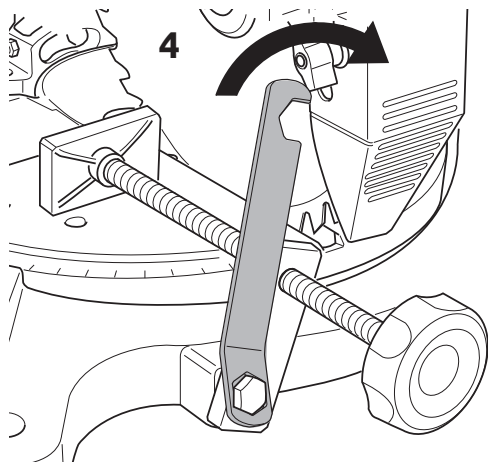
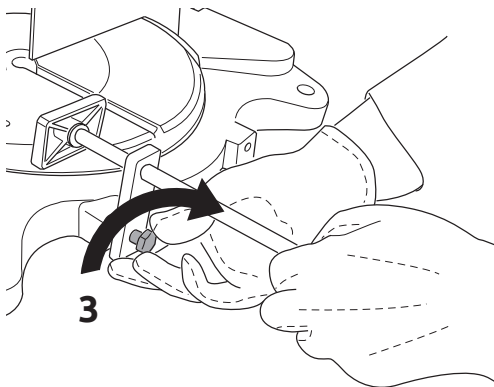
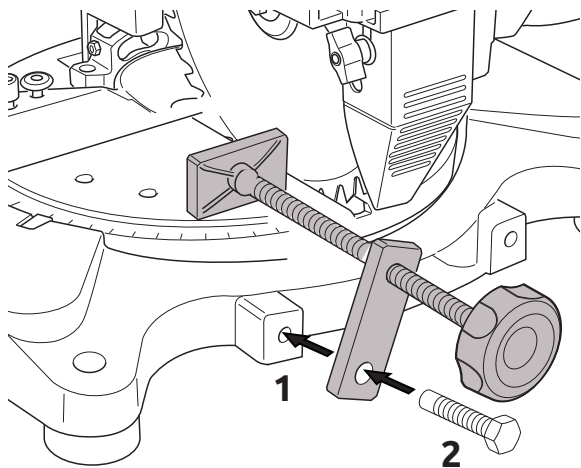
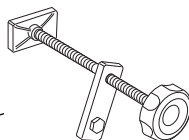

TTMS 254 PLUS / TTMS 254i PLUS

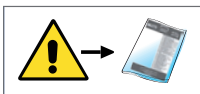
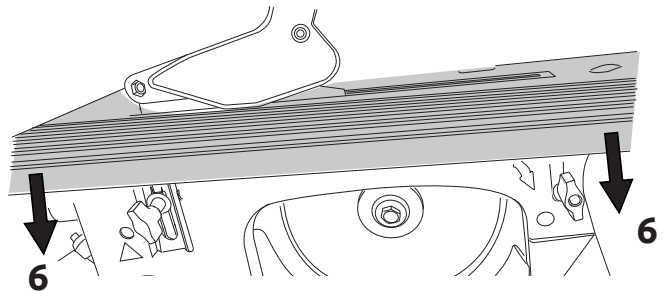
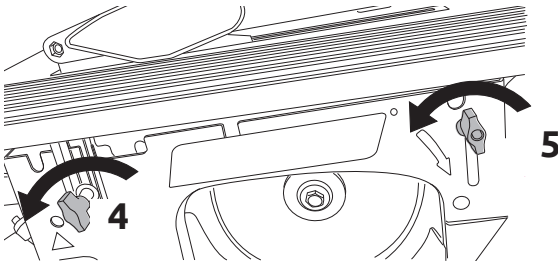
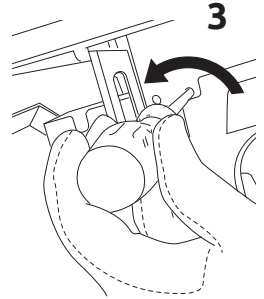
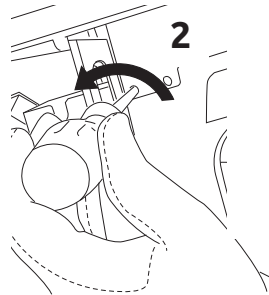
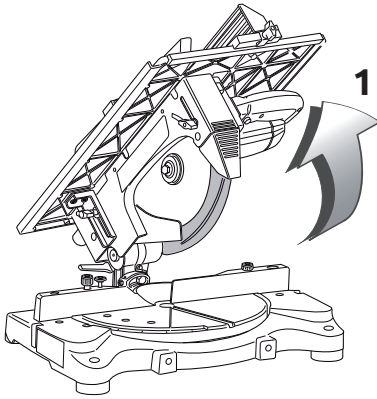

TTMS 254 PLUS / TTMS 254i PLUS

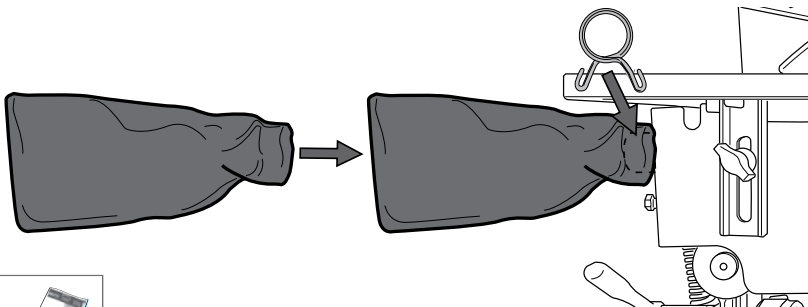
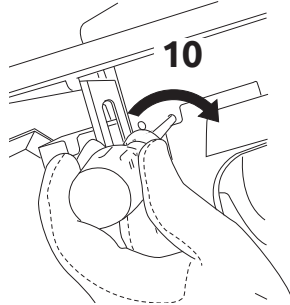
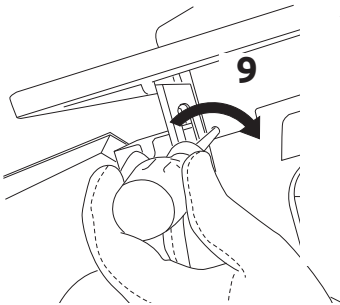
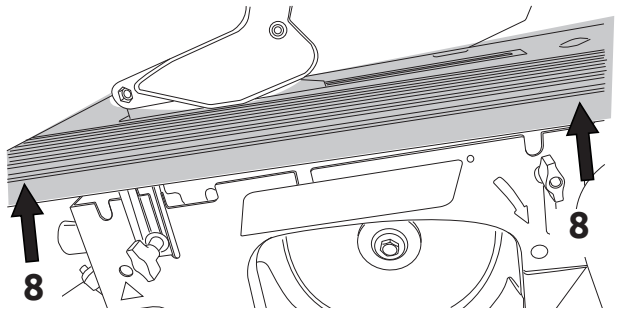
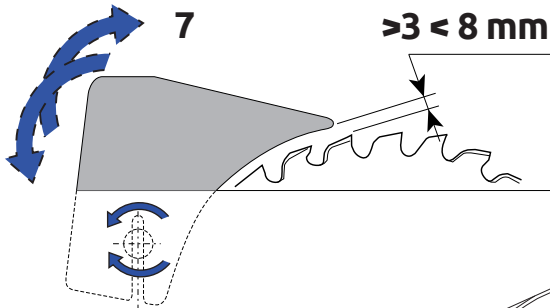

TTMS 254 PLUS / TTMS 254i PLUS

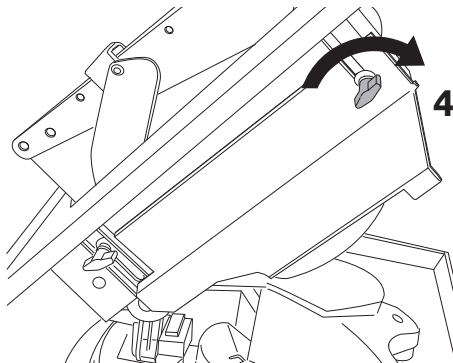
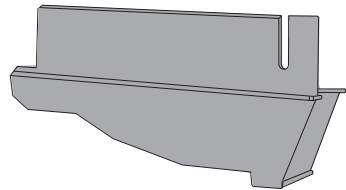
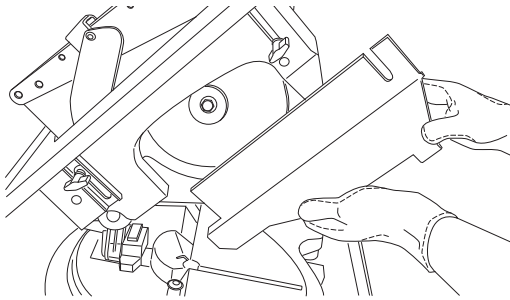
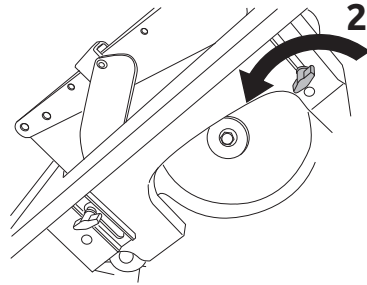
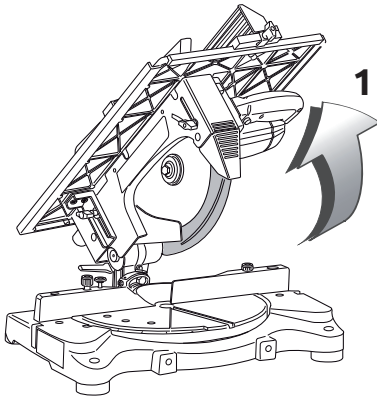
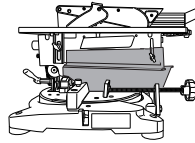

TTMS 254 PLUS / TTMS 254i PLUS

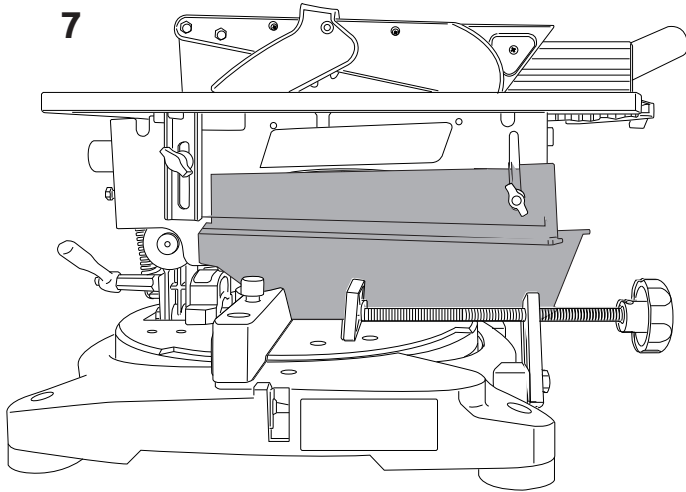
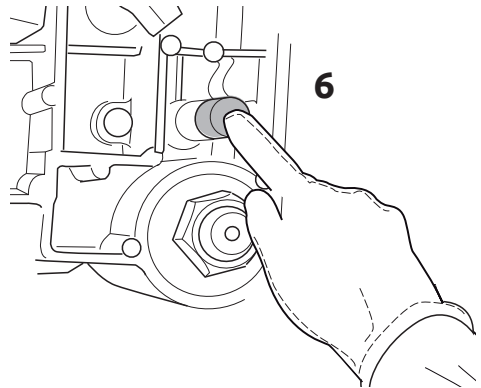
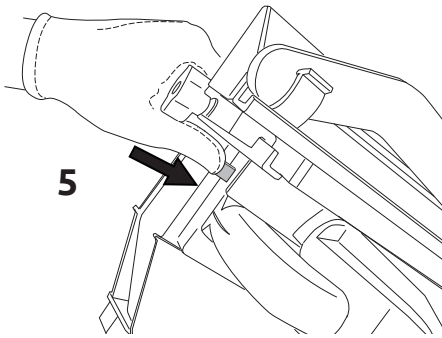
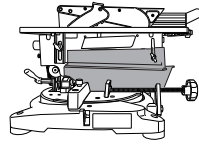

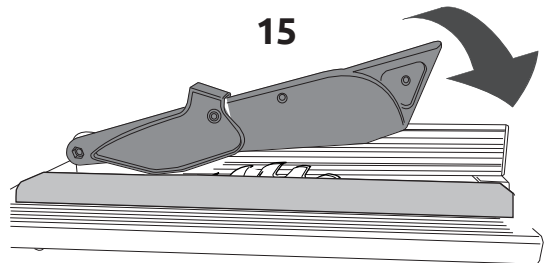
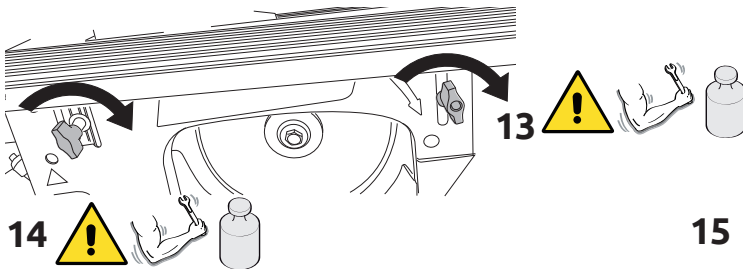
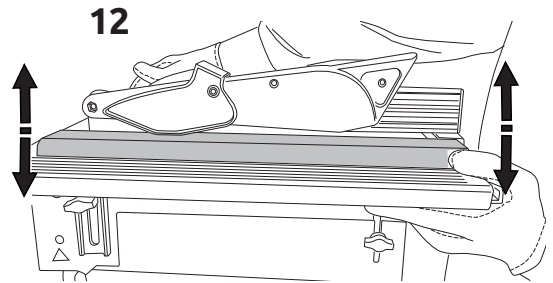
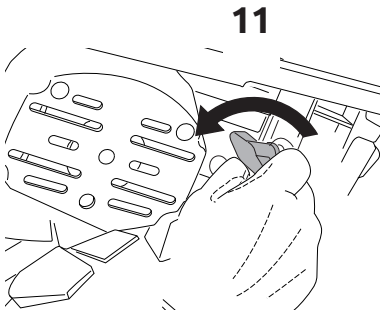
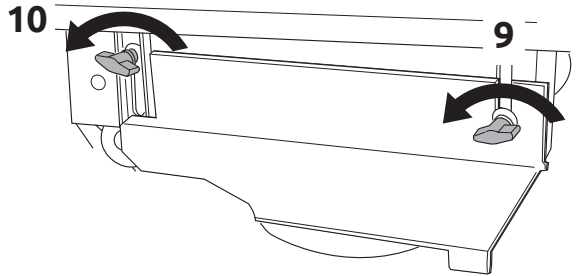
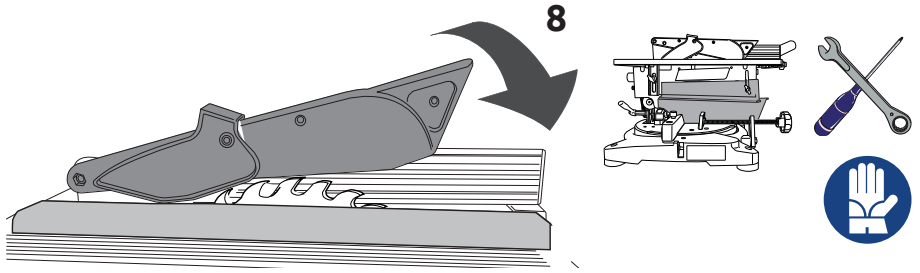

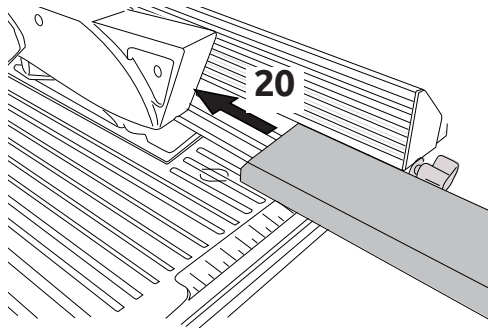
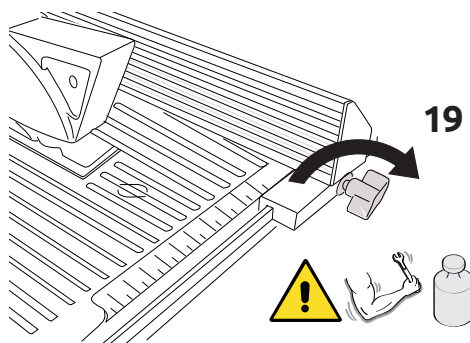
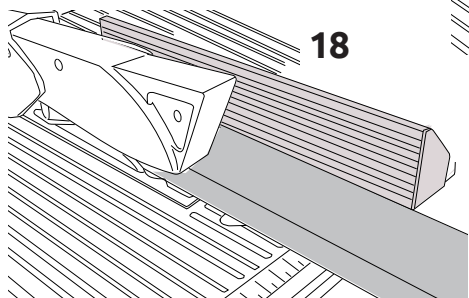
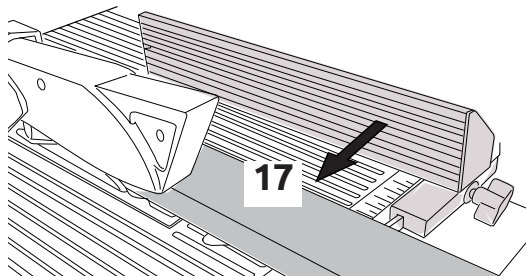
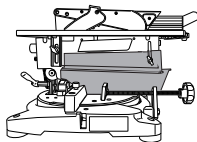
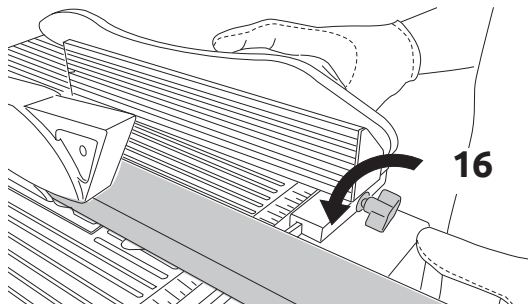



USO CONSENTITO - La macchina è stata progettata e costruita per il taglio in modalità troncatrice e sega da banco.

Modalità sega da banco: legno stagionato

Modalità troncatrice: legno stagionato, materie plastiche, alluminio e sue leghe

USO NON CONSENTITO - È vietato:

- lavorare materiali a base ferrosa.
- Lavorare materiali organici e/o alimentari.
- Lavorare materiali che possono, per effetto del taglio, emettere sostanze nocive.
- Lavorare in modalità sega a banco e tagliare legno umido.
- Utilizzare la macchina senza le protezioni in posizione.
- Utilizzare lame in acciaio rapido.
- Utilizzare la macchina per effettuare tagli ciechi.
- Utilizzare la modalità sega circolare per il taglio di materiali metallici.



La macchina non è adatta all'uso in ambiente con atmosfera potenzialmente esplosiva.

RISCHI RESIDUI

Rischio di cesoiamento taglio e sezionamento - Tale rischio è identificato con il simbolo:



Rischio di impigliamento trascinalimento ed intrappolamento: tale rischio è identificato con il simbolo:



Precauzioni da adottare

- Nella fase di taglio non utilizzare guanti da lavoro.
- Tenere lontano le mani dalla zona di lavoro.
- Non asportare residui di taglio o spezzoni con la lama in rotazione.

Rischio di schiacciamento: tale rischio è identificato con il simbolo:



Precauzioni da adottare

- Tenere lontano le mani dalla zona di rotazione della testa.

- Non avvicinare il volto alla zona di taglio;
- evitare assolutamente di avvicinare le mani alla zona di taglio prima che la testa sia alla massima altezza e la lama sia completamente ferma;
- ridurre la pressione nel momento di contatto tra lama e pezzo, per evitare la rottura della lama;
- alleggerire la pressione di taglio per salvaguardare la macchina.



INFORMAZIONI RELATIVE A RUMOROSITÀ - I valori indicati per il rumore sono livelli di emissione e non necessariamente livelli di lavoro sicuro. Mentre vi è una correlazione tra livelli di emissione e livelli di esposizione, questa non può essere usata affidabilmente per determinare se siano richieste o no ulteriori precauzioni. I fattori che influenzano il reale livello di esposizione del lavoratore includono la durata dell'esposizione, le caratteristiche dell'ambiente, altre sorgenti di rumore, per esempio il numero di macchine e altre lavorazioni adiacenti. Inoltre i livelli di esposizione possono variare da un Paese a Paese. Queste informazioni mettono comunque in grado l'utilizzatore della macchina di fare la miglior valutazione dei pericoli e dei rischi.



È opportuno l'uso dei mezzi personali di protezione dell'udito, come cuffie o inserti auricolari.

INFORMAZIONI SULLA COMPATIBILITÀ ELETTRIMAGNETICA - Le emissioni elettromagnetiche della macchina non superano i limiti definiti dalle norme per le condizioni di impiego previste.



Verificare che nell'impianto di alimentazione sia presente una protezione magnetotermica atta a salvaguardare tutti i conduttori dai corto circuiti e dai sovraccarichi.

Vibrazioni - Il valore medio quadratico ponderato in frequenza, dell'accelerazione mano braccio, in condizioni di taglio normale con lame correttamente affilate, risulta inferiore a 2,5 m/sec².

Le rilevazioni sono state eseguite utilizzando la norma UNI EN ISO 5349-1 e 5349-2.



Le vibrazioni durante l'uso reale della macchina possono essere diverse da quelle dichiarate, dal momento che il valore totale di vibrazione dipende dal modo in cui viene utilizzata la macchina. È necessario quindi identificare le misure di sicurezza più appropriate per proteggere l'operatore, basate su una stima dell'esposizione nelle condizioni reali di uso.



PERMITTED USE - This machine has been designed and manufactured for cutting operations in mitre saw or bench saw mode.

Bench saw mode: seasoned wood

Mitre saw mode: seasoned wood, plastic materials, aluminium and its alloys

UNINTENDED USE - IT is forbidden to:

- operate on ferrous materials.
- operate on organic materials and/or food stuffs.
- operate on materials which may release toxic substances during the cutting process.
- cut damp wood when using the machine in bench saw mode.
- use the machine when the safety guards are not in position.
- use high-speed steel blades.
- use the machine to make blind cuts.
- cut metal material when using the machine in circular saw mode.



This machine is not suitable for use in potentially explosive environments.

RESIDUAL RISKS

Shearing, cutting and severing hazard - Risk indicated by this symbol:



Entanglement, drawing-in and entrapment hazard: This risk is indicated by this symbol:



Precautions to be taken

- During the cutting phase do not wear work gloves.
- Keep hands away from the work area.
- Never remove cuttings or fragments from the machine when the blade is rotating.

Crushing hazard: This risk is indicated by this symbol:



Precautions to be taken

- Keep hands away from the head rotation area.
- Keep your face away from the cutting area;
- Never bring hands anywhere near the cutting zone until the head has returned to its full height and the blade has come to a complete standstill;
- To avoid breaking the blade, reduce pressure as soon as the blade comes into contact with the workpiece;
- Lessen the cutting pressure to safeguard the machine.



INFORMATION CONCERNING NOISE - The noise values indicated are emission levels and not necessarily safe operating levels. While there is a correlation between emission levels and exposure levels, this cannot reliably be used to determine whether or not further safety precautions are needed. Factors which influence the real level of a worker's exposure include the duration of exposure, the characteristics of the working environment, other sources of noise, for example the number of machines or operations being carried out in the near vicinity. Furthermore, levels of safe exposure may be fixed differently from one country to another. This information does however help the machine user to better assess the hazards and risks.



It is advisable to use suitable hearing protection such as earmuffs or ear plugs.

INFORMATION ON ELECTROMAGNETIC COMPATIBILITY - Electromagnetic emissions from the machine do not exceed the limits defined by the relative standards for the envisaged conditions of use.



Check that the power supply system is equipped with a thermomagnetic circuit breaker to protect all conductors from short circuit and overloads.

Vibrations - The mean frequency-weighted r.m.s. hand-arm acceleration value in normal cutting conditions using correctly sharpened blades, is less than 2.5 m/sec².

Test measurements were carried out in accordance with Standards EN ISO 5349-1 and EN ISO 5349-2.



Vibrations during real machine use may differ from those declared as the total vibration value depends very much on how the machine is used.

It is therefore necessary to identify the most appropriate safety measurements to safeguard the operator based on estimated exposure times and real conditions of use.



USAGE AUTORISÉ - La machine a été conçue et construite pour la coupe en mode tronçonneuse et scie à banc.

Mode scie à banc : bois sec

Mode tronçonneuse : bois sec, matières plastiques, aluminium et ses alliages

USAGE NON AUTORISÉ - IL EST interdit de :

- traiter des matériaux ferreux.
- Traiter des matériaux organiques et/ou alimentaires.
- Traiter des matériaux pouvant, par effet de la coupe, émettre des substances nocives.
- Traiter en mode scie à banc et couper du bois humide.
- Utiliser la machine sans les protections en position.
- Utiliser des lames en acier rapide.
- Utiliser la machine pour effectuer des coupes aveugles.
- Utiliser le mode scie circulaire pour la coupe de matériaux métalliques.

 La machine n'est pas indiquée à être utilisée dans un milieu avec une atmosphère potentiellement explosive.

RISQUES RÉSIDUELS

Risque de cisaillement, coupure et sectionnement - Ce risque est identifié par le symbole suivant : 

Risque d'accrochage, entraînement et emprisonnement : ce risque est identifié par le symbole suivant : 

Précautions à adopter

- Ne pas utiliser des gants de travail pendant la phase de coupe.
- Maintenir les mains éloignées de la zone de travail.
- Ne pas retirer des résidus ou des tronçons de coupe avec la lame en rotation.

Risque d'écrasement : ce risque est identifié par le symbole suivant : 

Précautions à adopter

- Maintenir les mains éloignées de la zone de rotation de la tête.
- Ne pas approcher le visage à la zone de coupe ;
- éviter absolument d'approcher les mains à la zone de coupe avant que la tête ait atteint la hauteur maximum et la lame soit complètement arrêtée ;
- réduire la pression au moment du contact entre la lame et la pièce à couper, afin d'éviter la rupture de la lame ;
- réduire la pression de coupe afin de sauvegarder la machine.

INFORMATIONS RELATIVES AU NIVEAU DE BRUIT - Les valeurs indiquées pour le bruit sont des niveaux d'émission et non pas nécessairement des niveaux de travail en sécurité. Il existe une corrélation entre les niveaux d'émission et les niveaux d'exposition, mais cette corrélation ne peut être utilisée de manière fiable pour déterminer si d'ultérieures précautions sont requises ou moins. Les facteurs qui influencent le niveau réel d'exposition du travailleur incluent la durée de l'exposition, les caractéristiques de l'environnement, la présence d'autres sources de bruit, par exemple le nombre de machine et d'autres usinages adjacents. En outre les niveaux d'exposition peuvent varier d'un Pays à l'autre. Ces informations permettent toutefois à l'utilisateur de la machine de faire la meilleure évaluation possible des dangers et des risques.

 Il est conseillé d'utiliser de dispositifs individuels de protection de l'ouïe, tels que casques ou tampons auriculaires.

INFORMATIONS SUR LA COMPATIBILITÉ ÉLECTROMAGNÉTIQUE - Les émissions électromagnétiques de la machine ne dépassent pas les limites définies par les normes pour les conditions d'usage prévues.

 Vérifier que dans l'installation d'alimentation soit présente une protection magnétothermique en mesure de sauvegarder tous les conducteurs contre les courts-circuits et les surcharges.

Vibrations - La valeur moyenne pondérée en fréquence, de l'accélération main bras, en conditions de coupe normale avec des lames correctement aiguisées, est inférieure à 2,5 m/sec².
Les relevés ont été effectués conformément aux normes UNI EN ISO 5349-1 et 5349-2.

 Les valeurs de vibration pendant l'usage réel de la machine peuvent être différentes de celles déclarées, car la valeur totale de vibration dépend de la manière dans laquelle la machine est utilisée. Il est donc nécessaire d'identifier les mesures de sécurité les plus appropriées afin de protéger l'opérateur, sur la base d'une évaluation de l'exposition dans les conditions réelles d'usage.



ПОЗВОЛЕНО ИЗПОЛЗВАНЕ - Машината е проектирана и произведена за рязане в режим циркуляр или настолен циркуляр.

Режим настолен циркуляр: суха дървесина

Режим циркуляр: суха дървесина, пластмаса, алуминий и сплави

НЕПРЕДВИДЕНА УПОТРЕБА - ЗАБРАНЕНО е:

- обработка материали от желязо
- Обработка на органични и/или хранителни материали материали.
- Обработка на материали, които в процес на обработка отделят вредни вещества.
- Обработка в режим циркуляр и настолен циркуляр и рязане на влажно дърво.
- Използване на машина без поставени защити.
- Използвайте остриета с високоскоростна стомана.
- Използвайте машината за рязане на слепи рязания.
- Използвайте циркуляра за рязане на метални материали.

 Машината не е подходяща за използване в среда с потенциално експлозивна атмосфера.

ОСТАТЪЧНИ РИСКОВЕ

Риск от отрязване, срязване и прерязване - Този риск е обозначен със символа:



Рискове за заплитане, уличане и захвашане: Този риск е обозначен със символа:



Необходими предпазни мерки

- Не използвайте работни ръкавици в процес на обработка.
- Дръжте ръцете си далеч от работната зона.
- При работещ въртящ се нож не вадете отпадъците от рязането или парчета от детайла.

Риск от счипване: Този риск е обозначен със символа:



Необходими предпазни мерки

- Дръжте ръцете си далеч от зоната на въртене на главата.
 - Не доближавайте лицето си до зоната на рязане;
 - в никакъв случай не доближавайте ръцете си до зоната на рязане, ако главата не е максимално вдигната нагоре и ножът не е напълно спрял;
- намалете налягането в момента на допир между ножа и детайла, за да избегнете счупване на ножа;
- намалете налягането при рязане, за да предпазите машината.



ИНФОРМАЦИЯ ОТНОСНО ШУМА - Посочените стойности за шум са нива на емисия, а не непременно сигурни нива, достигани при работа. Макар да съществува връзка между нивата на емисия и нивата на експозиция, то тя не може да бъде използвана като надеждно средство за определяне дали са необходими или не допълнителни предпазни мерки. Факторите, които влияят на реалното ниво на експозиция на работника включват продължителност на експозицията, характеристики на околната среда, други източници на шум, например броя на машините и други съпътстващи обработки. Освен това, допустимите нива на експозиция могат да бъдат различни в различните държави. Тази информация дава възможност на потребителя на машината да направи по-добра оценка на опасността и на рисковете.



Необходимо е използването на лични предпазни средства за защита на слуха, като антифони или тапи за уши.

ИНФОРМАЦИЯ ОТНОСНО ЕЛЕКТРОМАГНИТНАТА СЪВМЕСТИМОСТ - Електромагнитните емисии на машината не превишават границите, определени от стандартите за предвидените експлоатационни условия.



Проверете дали в захранващата верига има магнитотермична защита, която да предпазва всички проводници от късо съединение и претоварвания.

Вибрации - Средно претеглената квадратна стойност при ускорение ръка лост, при нормален процес на рязане и правилно наточени ножове е по-ниска от 2,5 м/сек². Стойностите са били измерени на базата на стандарти UNI EN ISO 5349-1 и 5349-2.



Вибрациите при нормален процес на работа на машината могат да се различават от обявените, като се има предвид, че общата стойност на вибрациите зависи от начина на употреба на машината. Следователно е необходимо да се установи кои са най-подходящите предпазни мерки, които да бъдат предприети за защита на оператора, което става чрез преценка на експозицията при реални работни условия.



DOPUŠTENA UPORABA - Stroj je dizajniran i konstruiran za rezanje na način preklopne i stolne pile.

Način stolne pile: trošno drvo

Način preklopne pile: trošno drvo, plastika, aluminij i njegove legure

NEDOZVOLJENA UPORABA – ZABRANJENO je:

- rad s materijalima željezne baze.
- Obradivati organske materijale i/ili materijale za prehrambene proizvode.
- Obradivati materijale koji mogu tijekom rezanja ispuštati štetne tvari.
- Rezati mokro drvo u načinu rada stolne pile.
- Koristiti stroj bez namještenih zaštita.
- Koristiti čelična sječiva velike brzine.
- Koristiti stroj za slijepe rezove.
- Koristiti način rada kružne pile za rezanje metalnih materijala.



Stroj nije prilagođen uporabi u prostoriji s potencijalno eksplozivnom atmosferom.

PREOSTALI RIZICI

Rizik od sječenja i rezanja – Navedeni rizik označen je simbolom:



Rizik od zaplitanja, zahvaćanja i ukliještenja: Navedeni rizik označen je simbolom:



Primjena mjera predostrožnosti

- Tijekom rezanja ne upotrebljavajte radne rukavice.
- Držite ruke dalje od radnog područja.
- Ne uklanjajte ostatke rezanja ili dijelove dok se sječivo okreće.

Rizik od drobljenja: Navedeni rizik označen je simbolom:



Primjena mjera predostrožnosti

- Držite ruke podalje od područja rotacije glave.

- Ne približavajte lice području u kojem se obavlja rezanje;
- ni u kojem slučaju ne približavajte ruke području u kojem se obavlja rezanje prije nego što glava ne bude u najvišem položaju, a sječivo potpuno zaustavljeno;
- smanjite pritisak u trenutku doticaja sječiva i obrađivanog dijela kako biste izbjegli pucanje sječiva;
- smanjite pritisak rezanja kako biste sačuvali stroj.



INFORMACIJE O BUCI - Naznačene vrijednosti predstavljaju razine emitirane buke i nisu nužno razine koje jamče siguran rad. Iako postoji uzročna veza između razina emitiranja i izloženosti, ona se ne može sa sigurnošću upotrebljavati radi utvrđivanja potrebe za primjenom dodatnih mjera predostrožnosti. Čimbenici, koji utječu na stvarnu razinu izloženosti radnika, uključuju trajanje izloženosti, svojstva ambijenta, ostale izvore buke kao što su broj strojeva i susjedne obrade. Također se razine izloženosti se mogu razlikovati od države do države. U svakom slučaju ove informacije omogućavaju korisniku stroja obavljanje najbolje procjene opasnosti i rizika.



Preporučuje se uporaba osobnih zaštitnih sredstava za sluh poput slušalica i čepića za uši.

INFORMACIJE O ELEKTROMAGNETSKOJ KOMPATIBILNOSTI - Elektromagnetske emisije stroja ne prekoračuju ograničenja propisana standardima za predviđene uvjete uporabe.



Provjerite je li se u sklop za napajanja nalazi magnetotermička zaštita koja štiti provodnike od kratkog spoja i preopterećenja.

Vibracije - Srednja korijenska vrijednost frekvencije i ubrzanja kraka tijekom normalnog rezanja s pravilno naoštrenim sječivima manja je od 2,5 m/sec². Ispitivanje je obavljeno primjenom standarda UNI EN ISO 5349-1 i 5349-2.



Vibracije tijekom stvarne uporabe stroja mogu se razlikovati od navedenih vibracija budući da ukupna vrijednost vibracija ovisi o načinu uporabe stroja. Stoga je važno utvrditi najprikladnije mjere sigurnosti kako bi se zaštitio rukovatelj na osnovi procjene u stvarnim uvjetima uporabe.



DOZVOLJENO KORIŠĆENJE - Mašina je projektovana i izrađena za sečenje po sistemu rezača i cirkulara.
 Režim cirkulara: zrelo drvo
 Režim cirkulara: zrelo drvo, plastika, aluminijum i njegove legure

NEDOZVOLJENO KORIŠĆENJE - Zabranjeno je:

- obrada materijala na bazi željeza.
- Obrađivanje organskih i/ili prehrambenih materijala.
- Obrađivanje materijala koji mogu prilikom sečenja da ispuštaju štetne supstance.
- Obrađivanje na cirkularu i sečenje vlažnog drveta.
- Korišćenje mašine bez zaštita na mestu.
- Korišćenje sečiva od brzog čelika.
- korišćenje mašine za rezanje na slepo.
- Korišćenje sistema kružne testere za rezanje metalnih materijala.



Mašina nije prilagođena za upotrebu u okolini sa potencijalno eksplozivnom atmosferom.

REZIDUALNI RIZICI

Rizik od povreda nastalih od sečenja i kidanja - Takav rizik je označen simbolom:



Rizik od zaplitanja, povlačenja i zaglavljivanja: takav rizik je označen simbolom:



Predostrožnosti koje treba usvojiti

- Prilikom faze rezanja ne koristite rukavice za rad.
- Držite daleko ruke od radne zone.
- Nemojte uklanjati ostataka od rezanja ili isječke sa oštricom u rotaciji.

Rizik od gnečenja: takav rizik je označen simbolom:



Predostrožnosti koje treba usvojiti

- Držite podalje ruke od zone rotacije glave.



- Ne približavajte lice zoni rezanja;
- u potpunosti izbegavati približavanje ruku zoni rezanja pre nego što glava bude na maksimalnoj visini i sečivo bude potpuno zaustavljeno;
- smanjiti pritisak u trenutku kontakta između sečiva i komada, da bi se izbeglo lomljenje sečiva;
- smanjiti pritisak rezanja kako bi se sačuvala mašina.

INFORMACIJE U VEZI SA BUKOM - Naznačene vrednosti za buku su nivoi emisije buke a ne nužno nivoi bezbednog rada. Iako postoji korelacija između nivoa emisija i nivoa izloženosti, ona se ne može pouzdano koristiti za određivanje da li su ili ne potrebne dodatne mere predostrožnosti. Faktori koji utiču na stvarni nivo izloženosti radnika, obuhvataju trajanje izloženosti, karakteristike životne sredine, ostale izvore buke, na primer broj mašina i drugih susednih procesa obrade. Takođe, nivo izloženosti može da varira od zemlje do zemlje. Ove informacije daju svakako mogućnost korisniku mašine da uradi najbolju procenu opasnosti i rizika.



Prikladna je upotreba ličnih sredstava zaštite sluha, kao što su zaštita ili čepići za uši.

INFORMACIJE O ELEKTROMAGNETSKOJ KOMPATIBILNOSTI - Elektromagnetske emisije mašine ne prelaze granice definisane standardima za predviđene uslove korišćenja.



Proverite da li u uređaju za napajanje postoji magnetno termička zaštita prilagođena za čuva sve provodnike od kratkih spojeva i preopterećenja.

Vibracije - Ponderisana srednja kvadratna vrednost frekvencije, ručnog ubrzanja mehanizma, u uslovima normalnog rezanja sečivima ispravno naoštrenim, je manja za 2,5 m/sec².

Merenja su izvršena na osnovu standarda UNI EN ISO 5349-1 i 5349-2.



Vibracije tokom stvarne upotrebe mašine mogu da se razlikuju od onih koje su izjavljene, budući da ukupna vrednost vibracija zavisi od načina na koji se koristi mašina. Zbog toga je neophodno da se identifikuju najviše odgovarajuće bezbednosne mere za zaštitu operatera, na osnovu procene izloženosti u stvarnim uslovima korišćenja.



ΕΠΙΤΡΕΠΟΜΕΝΗ ΧΡΗΣΗ - Η μηχανή έχει σχεδιαστεί και κατασκευαστεί για κοπή στον τρόπο λειτουργίας μηχανής κοπής και επιτραπέζιου πριονιού.

Τρόπος λειτουργίας επιτραπέζιου πριονιού: παλαιωμένο ξύλο

Τρόπος λειτουργίας μηχανής κοπής: παλαιωμένο ξύλο, πλαστικά υλικά, αλουμίνιο και τα κράματά του

ΜΗ ΕΠΙΤΡΕΠΟΜΕΝΗ ΧΡΗΣΗ - απαγορεύεται:

- Η επεξεργασία υλικών με φάση το σίδερο.
- Η επεξεργασία υλικών οργανικών και/ή τροφίμων.
- Η επεξεργασία υλικών τα οποία ενδέχεται, λόγω της κοπής να απελευθερώσουν βλαβερές ουσίες.
- Η επεξεργασία σε τρόπο λειτουργίας επιτραπέζιου πριονιού και κοπή υγρού ξύλου.
- Η χρήση του μηχανήματος χωρίς τις προστασίες στη θέση τους.
- Η χρήση λεπίδων από ταχυαλύβα.
- Η χρήση του μηχανήματος για ένθετα δίπτυχα.
- Η χρήση στον τρόπο λειτουργίας κυκλικού πριονιού για κοπή μεταλλικών υλικών.



Η μηχανή δεν είναι κατάλληλη για χρήση σε δυνητικά εκρηκτική ατμόσφαιρα.

ΥΠΟΛΕΙΜΜΑΤΙΚΟΙ ΚΙΝΔΥΝΟΙ

Κίνδυνος κοψίματος και αποκοπής - Αυτός ο κίνδυνος προσδιορίζεται με το σύμβολο:



Κίνδυνος ενσφήνωσης, τραβήγματος και εγκλωβισμού: Αυτός ο κίνδυνος προσδιορίζεται με το σύμβολο:



Προφυλάξεις προς υιοθέτηση

- Στη φάση της κοπής, μη χρησιμοποιείτε γάντια εργασίας.
- Κρατήστε τα χέρια σας μακριά από την περιοχή εργασίας.
- Μην αφαιρείτε τα υπολείμματα κοπής ή τεμάχια με τη λεπίδα σε περιστροφή.

Κίνδυνος σύνθλιψης: Αυτός ο κίνδυνος προσδιορίζεται με το σύμβολο:



Προφυλάξεις προς υιοθέτηση

- Κρατήστε τα χέρια σας μακριά από την περιοχή περιστροφής της κεφαλής.

- Μην προσεγγίζετε το πρόσωπο στην περιοχή κοπής;
- αποφύγετε ρητά την προσέγγιση των χεριών στην περιοχή κοπής πριν το κεφάλι να είναι στο μέγιστο ύψος και η λεπίδα εντελώς σταματημένη
- μειώστε την πίεση κατά τη στιγμή της επαφής μεταξύ λεπίδας και τεμαχίου, για να αποφύγετε το σπάσιμο της λεπίδας
- χαλαρώστε την πίεση κοπής για να διαφυλάξετε το μηχανήμα.



ΠΛΗΡΟΦΟΡΙΕΣ ΣΧΕΤΙΚΑ ΜΕ ΤΟ ΘΟΡΥΒΟ - Οι τιμές που αναφέρονται για το θόρυβο είναι επίπεδα εκπομπών θορύβου και όχι απαραίτητα ασφαλή επίπεδα εργασίας. Ενώ υπάρχει συσχέτιση μεταξύ των επιπέδων εκπομπών και των επιπέδων έκθεσης, αυτό δεν μπορεί να χρησιμοποιηθεί με αξιοπιστία για να καθορισθεί εάν απαιτούνται ή όχι περισσότερες προφυλάξεις. Οι παράγοντες που επηρεάζουν το πραγματικό επίπεδο της έκθεσης του εργαζομένου περιλαμβάνουν τη διάρκεια της έκθεσης, τα χαρακτηριστικά του περιβάλλοντος, άλλες πηγές θορύβου, για παράδειγμα, τον αριθμό των μηχανών και άλλων γειτονικών διεργασιών. Επιπλέον, τα επίπεδα έκθεσης μπορούν να ποικίλουν από χώρα σε χώρα. Αυτή η πληροφορία καθιστά τον χειριστή ικανό να χειριστεί την μηχανή και να κάνει την καλύτερη εκτίμηση των κινδύνων και των ρίσκων.



Θα πρέπει να χρησιμοποιηθούν μέσα ατομικής προστασίας της ακοής, όπως ακουστικά ή ωτοασπίδες.

ΠΛΗΡΟΦΟΡΙΕΣ ΣΧΕΤΙΚΑ ΜΕ ΤΗΝ ΗΛΕΚΤΡΟΜΑΓΝΗΤΙΚΗ ΣΥΜΒΑΤΟΤΗΤΑ - Οι ηλεκτρομαγνητικές εκπομπές από το μηχάνημα δεν υπερβαίνουν τα όρια που ορίζονται από τα πρότυπα για τις προβλεπόμενες συνθήκες χρήσης.



Βεβαιωθείτε ότι στο σύστημα τροφοδοσίας υφίσταται μια μαγνητοθερμική προστασία για την προστασία όλων των αγωγών από τα βραχυκυκλώματα υπερθέρμανσης.

Κραδασμοί - Ενεργή μέση τιμή συχνότητας της επιτάχυνσης χειριού-βραχίονα σε συνθήκες κανονικής κοπής με λεπίδες σωστά ακονισμένες, είναι χαμηλότερο του $2,5 \text{ m/sec}^2$.
Οι δοκιμές διεξήχθησαν κατά UNI EN ISO 5349-1 και 5349-2.



Οι κραδασμοί κατά την πραγματική χρήση του μηχανήματος μπορεί να είναι διαφορετικοί από εκείνους που έχουν δηλωθεί, από τη στιγμή που η συνολική τιμή των κραδασμών εξαρτάται από τον τρόπο με τον οποίο χρησιμοποιείται το μηχάνημα.

Θα πρέπει, επομένως να προσδιορίσετε τα καταλληλότερα μέτρα ασφαλείας για την προστασία που χειριστή, με βάσει μία αξιολόγηση της έκθεσης σε πραγματικές συνθήκες χρήσης.



UTILIZARE PERMISĂ - Mașina a fost proiectată și construită pentru tăierea în modul mașină de tăiat și fierăstrău de banc.

Mod fierăstrău de banc: lemn uscat

Mod mașină de tăiat: lemn uscat, materiale plastice, aluminiul și aliajele sale

UTILIZARE NEPERMISĂ - SE interzice:

- prelucrarea materialelor bază feroasă.
- Prelucrarea materialelor organice și/sau alimentare.
- Prelucrarea materialelor care pot, ca urmare a tăierii, să emită substanțe nocive.
- Prelucrarea în modul fierăstrău de banc și tăierea lemnului umed.
- Utilizați mașina fără protecții în poziție.
- Utilizați lame de oțel de mare viteză.
- Utilizați mașina pentru a efectua tăieri oarbe.
- Utilizați modul fierăstrău circular pentru tăierea materialelor metalice.



Mașina nu este potrivită pentru utilizarea într-un mediu cu atmosferă potențial explozivă.

RISURI REZIDUALE

Risc de rețezare, tăiere și secționare - Acest risc este identificat cu simbolul:



Risc de agățare, tragere și prindere: acest risc este identificat cu simbolul:



Măsuri de precauție ce trebuie adoptate

- În faza de tăiere, nu utilizați mănuși de lucru.
- Țineți mâinile la distanță de zona de lucru.
- Nu îndepărtați reziduurile de tăiere sau resturile cu lama care se rotește.

Risc de strivire: Acest risc este identificat cu simbolul:



Măsuri de precauție ce trebuie adoptate

- Țineți degetele departe de zona de rotație a capului.



- Nu apropiați fața de zona de tăiere;
- evitați sub orice formă să apropiați mâinile de zona de tăiere înainte ca lama să se fi oprit complet și capul să fie la înălțimea maximă;
- reduceți presiunea în momentul contactului dintre lamă și piesă, pentru a evita ruperea lamei;
- reduceți presiunea de tăiere pentru a proteja mașina.

INFORMAȚII REFERITOARE LA ZGOMOT - Valorile indicate pentru zgomot sunt niveluri de emisie de zgomot și nu sunt în mod necesar niveluri de lucru în condiții de siguranță. Deși există o corelație între nivelurile de emisie și cele de expunere, acest lucru nu poate fi utilizat în mod fiabil pentru a determina dacă sunt necesare sau nu măsuri de precauție suplimentare. Factorii care influențează nivelul actual de expunere a operatorului includ durata de expunere, caracteristicile mediului, alte surse de zgomot, de ex. numărul de mașini și alte procese adiacente. Mai mult decât atât, nivelurile de expunere pot varia de la o țară la alta. Aceste informații permit, totuși, utilizatorul aparatului să evalueze cât mai bine pericolele și riscurile.



Se recomandă utilizarea echipamentelor de protecție personală pentru auz, precum căști sau dopuri pentru urechi.

INFORMAȚII PRIVIND COMPATIBILITATEA ELECTROMAGNETICĂ - Emisiile electromagnetice ale mașinii nu depășesc limitele definite de normele pentru condițiile de utilizare prevăzute.



Verificați ca în cadrul instalației de alimentare să fie prezentă o protecție magnetotermică în măsură să protejeze toți conductorii împotriva scurtcircuitului și a supraîncărcării.

Vibrații - Valoarea medie pătratică ponderată cu frecvența a accelerației mână-brăț, în condiții de tăiere normală cu lame corect ascuțite, este mai mică de 2,5 m/sec².

Măsurătorile au fost efectuate folosind norma UNI EN ISO 5349-1 și 5349-2.



Vibrațiile în timpul utilizării efective a mașinii pot fi diferite de cele declarate, din moment ce valoarea totală a vibrațiilor depinde de modul în care este utilizată mașina. Prin urmare, trebuie să se identifice măsurile de siguranță cele mai adecvate pentru protejarea operatorului, bazate pe o estimare a expunerii în condiții reale de utilizare.



RENDELTETÉSSZERŰ HASZNÁLAT - A gépet úgy terveztük és készítettük el, hogy gérvágó és asztali körfűrész üzemmódban is lehessen vágásra használni.

Asztali körfűrész üzemmódban: szárított fa

Gérvágó üzemmódban: szárított fa, műanyagok, alumínium és ötvözetek vágására

NEM RENDELTETÉSSZERŰ HASZNÁLAT - tilos:

- vastartalmú anyagok megmunkálására használni.
- Szerves anyagokat és/vagy élelmiszereket megmunkálni.
- Olyan anyagokat megmunkálni, amelyek a vágás során káros anyagokat bocsáthatnak ki.
- Asztali körfűrész üzemmódban dolgozni, és nedves fát vágni.
- A gépet használni, ha a védőburkolatok nincsenek a helyükön.
- Gyorsacél fűrészlapokat használni.
- A gépet horonyvágásra használni.
- Fémes anyagok vágásához körfűrész üzemmódban használja a gépet.



A gépet nem lehet robbanásveszélyes légkörű helyiségben használni.

FENNMARADÓ KOCKÁZATOK

Elnyírás, vágás és darabolás kockázata - Erre a kockázatra a következő jel figyelmeztet: 

Beakadás, elhúzás és beszorulás kockázata: erre a kockázatra a következő jel figyelmeztet: 

Elővigyázatossági intézkedések, amelyeket be kell tartani

- Vágásnál ne használjon munkavédelmi kesztyűt.
- A kezét tartsa távol a munkaterülettől.
- Ne távolítsa el vágási maradványokat vagy nagyobb darabot miközben a fűrészlap forog.

Zúzóadásos sérülés kockázata: Erre a kockázatra a következő jel figyelmeztet: 

Elővigyázatossági intézkedések, amelyeket be kell tartani

- A kezét tartsa távol a vágófej forgásának területétől.

- Arcát sose helyezze a vágóterület közelébe;



- soha ne közelítse kezét a munkaterülethez egészen addig, amíg a vágófej nincs a legmagasabb pozícióban és a fűrészlap nem állt meg teljesen;
- csökkentse a nyomást, amikor a fűrészlap a munkadarabhoz ér, hogy el ne törjön a fűrészlap;
- a gép megóvása érdekében csökkentse a vágás nyomását.

ZAJKIBOCSÁTÁSSAL KAPCSOLATOS INFORMÁCIÓK - A feltüntetett zajértékek kibocsátási értékek, és nem feltétlenül felelnek meg a biztonságos munkavégzés feltételeinek. Bár összefüggés van a kibocsátási szint és az expozíció szintje között, ez az összefüggés nem használható megbízhatóan annak eldöntéséhez, hogy szükség van-e további óvintézkedések meghatározására. A dolgozóra vonatkozó tényleges expozíciós értéket meghatározó tényezők a következők: az expozíció időtartama, a környezeti jellemzői, más zajforrások, például a gépek száma és egyéb közeli munkavégzések. Az expozíció határértékei különbözőek lehetnek az egyes országokban. Ezen információk lehetővé teszik a gép használója részére, hogy a legpontosabban felmérje a veszélyeket és a kockázatokat.



Javasoljuk hallásvédő egyéni védőeszközök, mint pl. fülvédő vagy fül dugó használatát.

ELEKTROMÁGNESES ÖSSZEFÉRHETŐSÉGGEL KAPCSOLATOS INFORMÁCIÓK - A gép elektromágneses kibocsátása nem haladja meg a szabványokban a rendeltetés szerű használatához előírt szintet.



Ellenőrizze, hogy a táphálózaton van-e olyan automata biztosíték, amely megvédi a vezetékeket a rövidzárlattól és a túlterheléstől.

Rezgés - A kéz/kar rezgésszám súlyozott gyorsulás négyzetes középértéke normális vágási körülmények és megfelelően éles fűrészlapok esetén alacsonyabb 2,5 m/sec²-nél.

A mérések az MSZ EN ISO 5349-1 és az 5349-2 szabványok szerint lettek elvégezve.



A gép használata közben fellépő rezgések eltérhetnek a nyilatkozatban feltüntetett rezgésértékektől, mivel a rezgések összességének értéke függ attól, hogy milyen módon használja a gépet. Ezért a használat tényleges körülményei alapján becsült expozíció alapján kell meghatározni a kezelő védelmét szolgáló legmegfelelőbb biztonsági intézkedéseket.

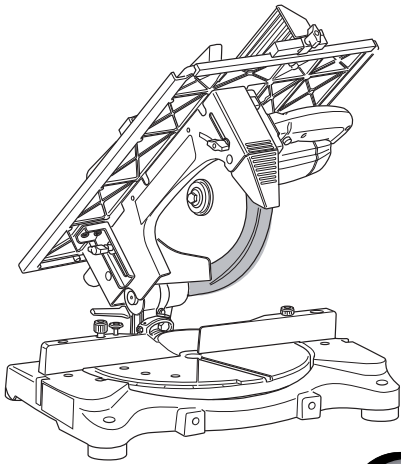

TTMS 254 PLUS

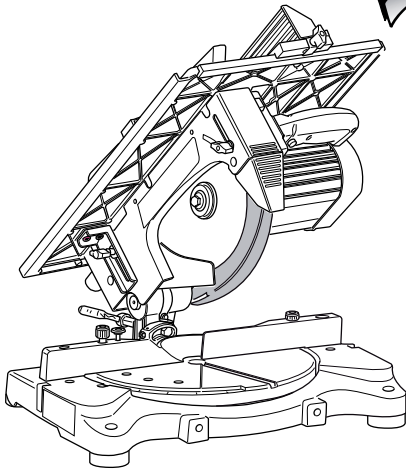

TTMS 254i PLUS

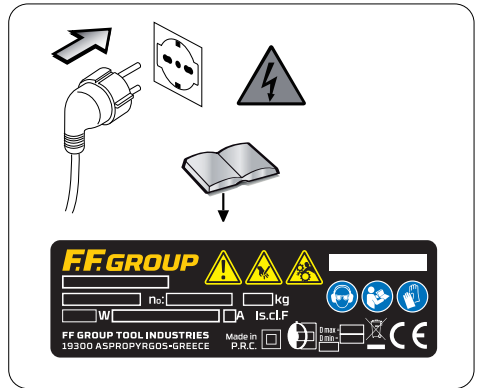

TTMS 254 PLUS / TTMS 254i PLUS

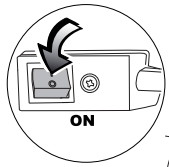
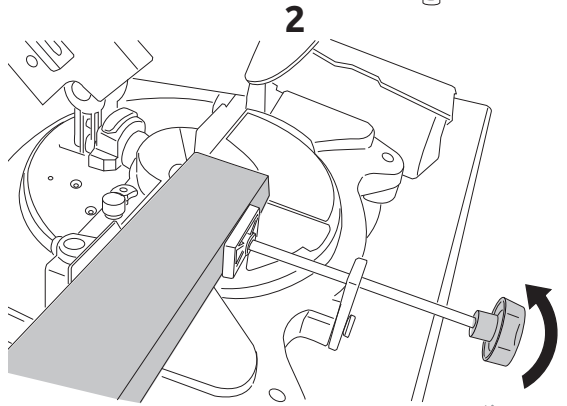
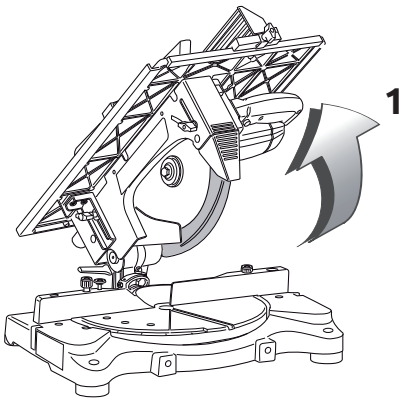
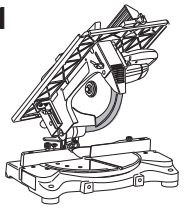
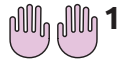

3

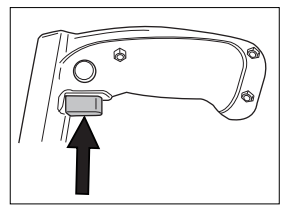
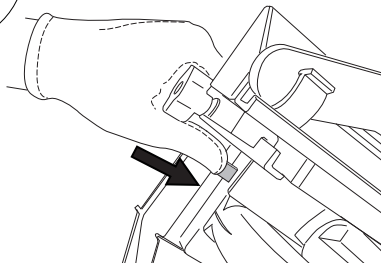

4

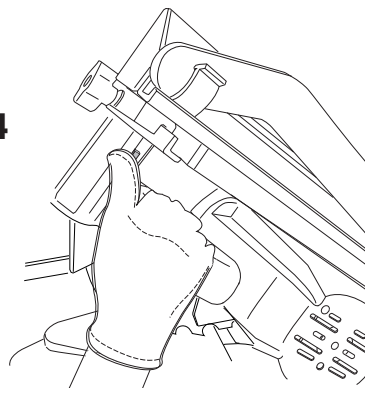

TTMS 254 PLUS / TTMS 254i PLUS

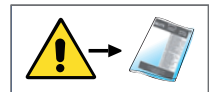
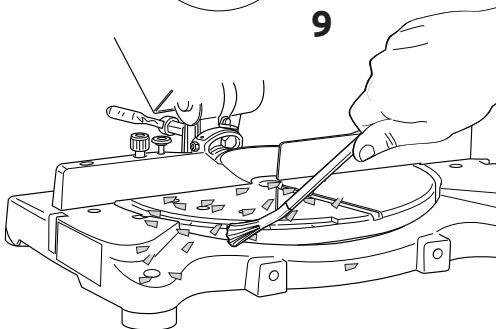
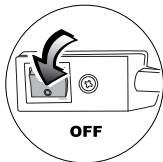
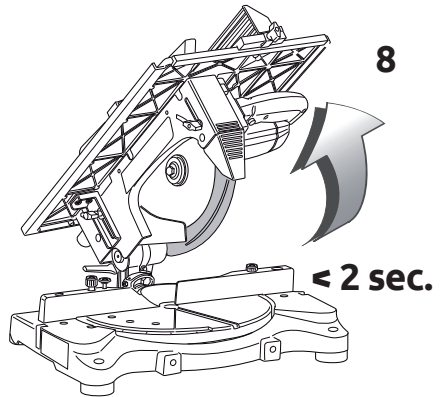
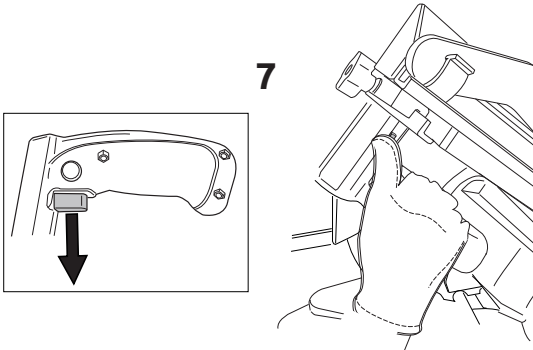
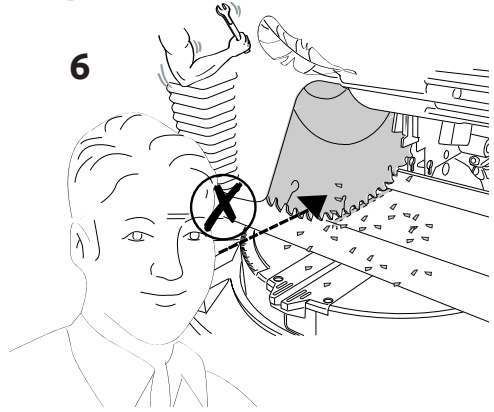
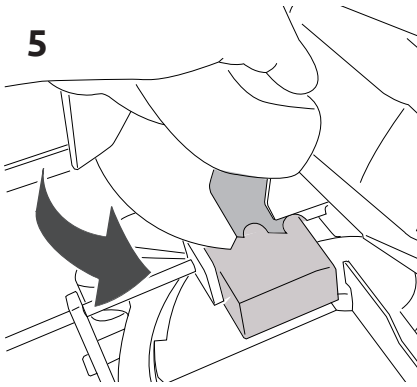
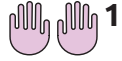

TTMS 254 PLUS / TTMS 254i PLUS

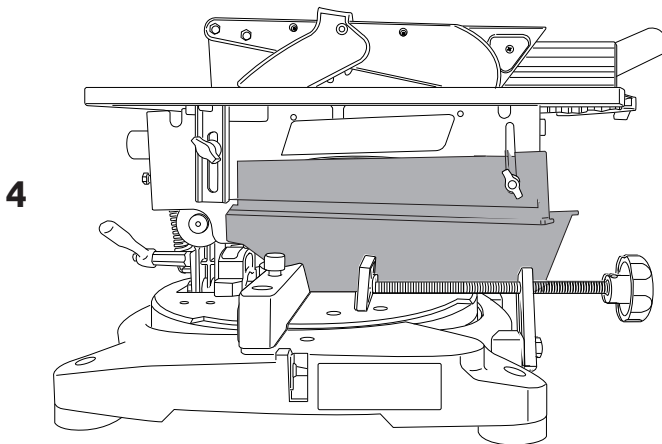
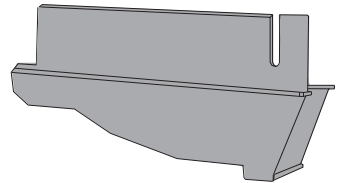
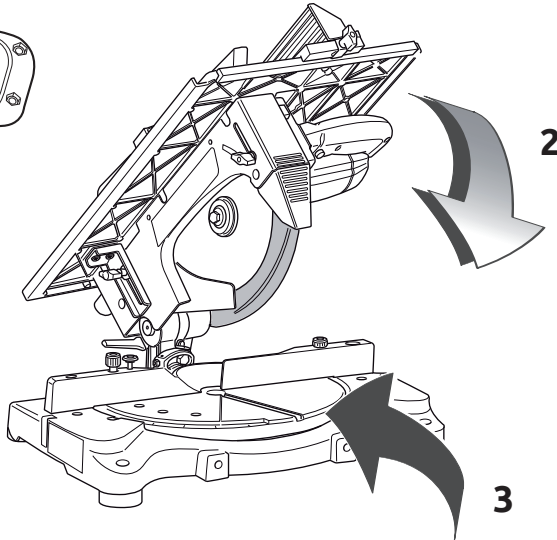
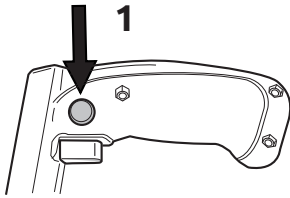
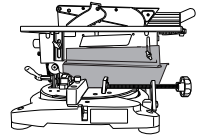
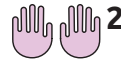

TTMS 254 PLUS / TTMS 254i PLUS

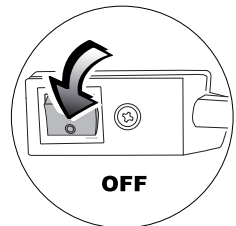
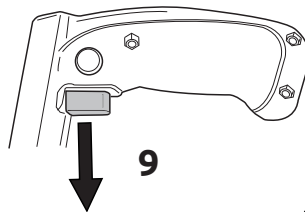
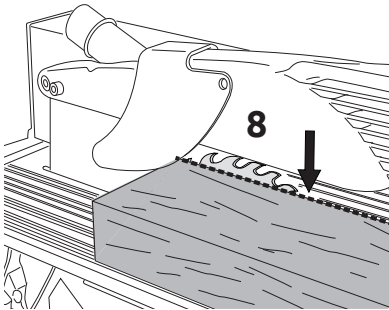
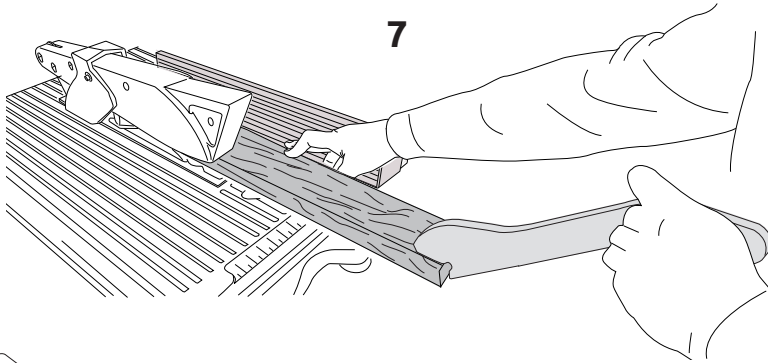
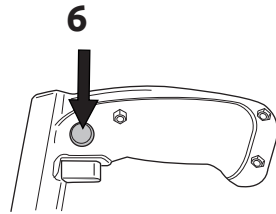
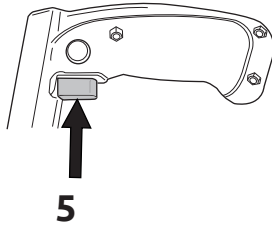
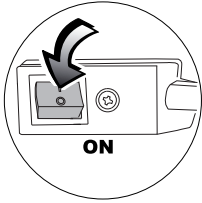

TTMS 254 PLUS / TTMS 254i PLUS

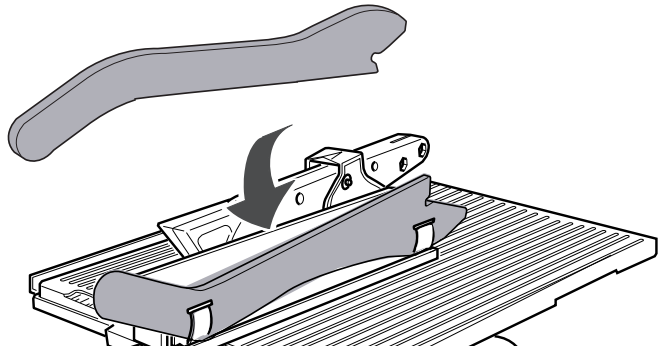

IT MANUTENZIONE

PRIMA DI ESEGUIRE QUALSIASI INTERVENTO DI MANUTENZIONE, FERMARE LA MACCHINA E FARLA RAFFREDDARE.



- Indossare i guanti di protezione.
- Verificare la compatibilità della lama usata.
- Verificare la compatibilità della lama nuova.
- Verificare l'integrità e la funzionalità delle protezioni.

EN MAINTENANCE

BEFORE PERFORMING ANY MAINTENANCE WORK, STOP THE MACHINE AND LET IT COOL DOWN.



- Wear protective gloves.
- Check the compatibility of the used blade.
- Check the compatibility of the new blade.
- Check that safeguards are in good condition and working order.

FR ENTRETIEN

AVANT D'EFFECTUER TOUTE INTERVENTION D'ENTRETIEN, IL EST NÉCESSAIRE D'ARRÊTER LA MACHINE ET DE LA LAISSER REFROIDIR.



- Porter les gants de protection.
- Vérifier que la lame utilisée soit compatible.
- Vérifier que la nouvelle lame soit compatible.
- Vérifier l'intégrité et la fonctionnalité des protections.

BG ПОДДРЪЖКА

ПРЕДИ ДА ИЗВЪРШИТЕ КАКВАТО И ДА Е ОПЕРАЦИЯ ПО ПОДДРЪЖКА, СПРЕТЕ МАШИНАТА И Я ОСТАВЕТЕ ДА ИЗСТИНЕ.



- Носете защитни ръкавици.
- Проверете съвместимостта на използваният нож.
- Проверете съвместимостта на новият нож.
- Проверете целостта и действието на защитите.

HR ODRŽAVANJE

PRIJE IZVOĐENJA BILO KOJEG POSTUPKA ODRŽAVANJA ZAUSTAVITE STROJ I PUSTITE GA DA SE OHLADI.



- Nosite zaštitne rukavice.
- Provjerite kompatibilnost korištenog sječiva.
- Provjerite kompatibilnost novog sječiva.
- Provjerite cjelovitost i funkcionalnost zaštita.

SR ODRŽAVANJE

PRE IZVRŠAVANJA BILO KOJE INTERVENCIJE NA ODRŽAVANJU, ZAUSTAVITI MAŠINU I PUSTITI JE DA SE OHLADI.



- Nositi zaštitne rukavice.
- Proverite kompatibilnost korišćenog sečiva.
- Proverite kompatibilnost novog sečiva.
- Proverite celovitost i funkcionalnost zaštita. .

EL ΣΥΝΤΗΡΗΣΗ

ΠΡΙΝ ΑΠΟ ΚΑΘΕ ΣΥΝΤΗΡΗΣΗ, ΣΤΑΜΑΤΗΣΤΕ ΤΗ ΜΗΧΑΝΗ ΚΑΙ ΑΦΗΣΤΕ ΤΗΝ ΝΑ ΚΡΥΩΣΕΙ.



- Φορέστε γάντια προστασίας.
- Ελέγξτε τη συμβατότητα της λεπίδας που χρησιμοποιήθηκε.
- Ελέγξτε τη συμβατότητα της καινούργιας λεπίδας.
- Βεβαιωθείτε για την ακεραιότητα και τη λειτουργικότητα των προστασιών.

RO ÎNTREȚINERE

ÎNAINTE DE EFECTUAREA ORICĂREI INTERVENȚII DE ÎNTREȚINERE, OPRIȚI MAȘINA ȘI LĂSAȚI-O SĂ SE RĂCEASCĂ.



- Purtați mănuși de protecție.
- Verificați compatibilitatea lamei utilizate.
- Verificați compatibilitatea lamei noi.
- Verificați integritatea și funcționalitatea protecțiilor.

HU KARBANTARTÁS

MIELŐTT BÁRMILYEN KARBANTARTÁSI MŰVELETET ELKEZDENE, ÁLLÍTSA LE A GÉPET, ÉS VÁRJA MEG, HOGY KIHŰLJÖN.



- Viseljen védőkesztyűt.
- Ellenőrizze, hogy a használt fűrészlap megfelelő-e.
- Ellenőrizze, hogy az új fűrészlap megfelelő-e.
- Ellenőrizze, hogy a védőburkolatok épek-e és működésképesek-e.

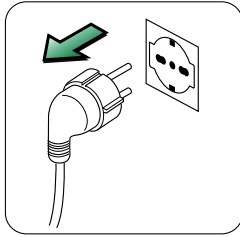

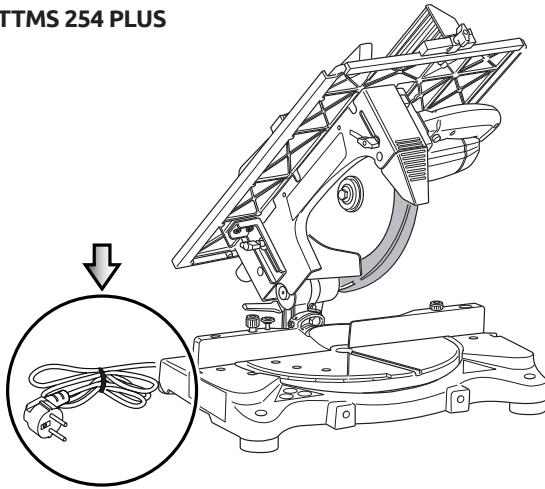

TTMS 254 PLUS

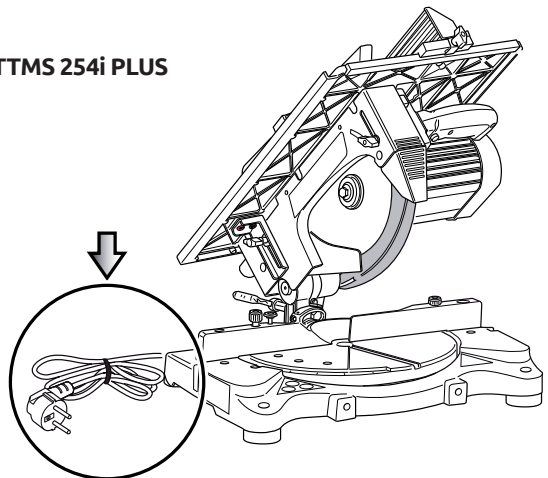

TTMS 254i PLUS

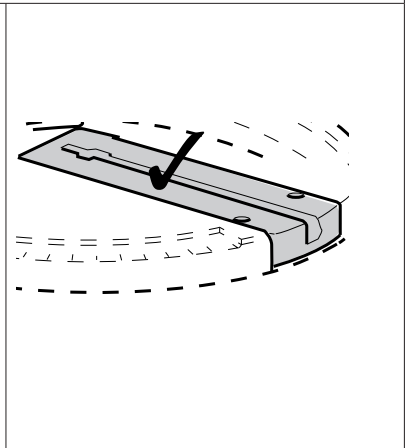
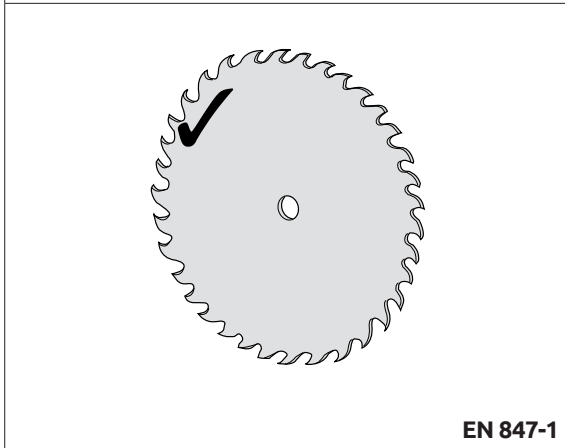
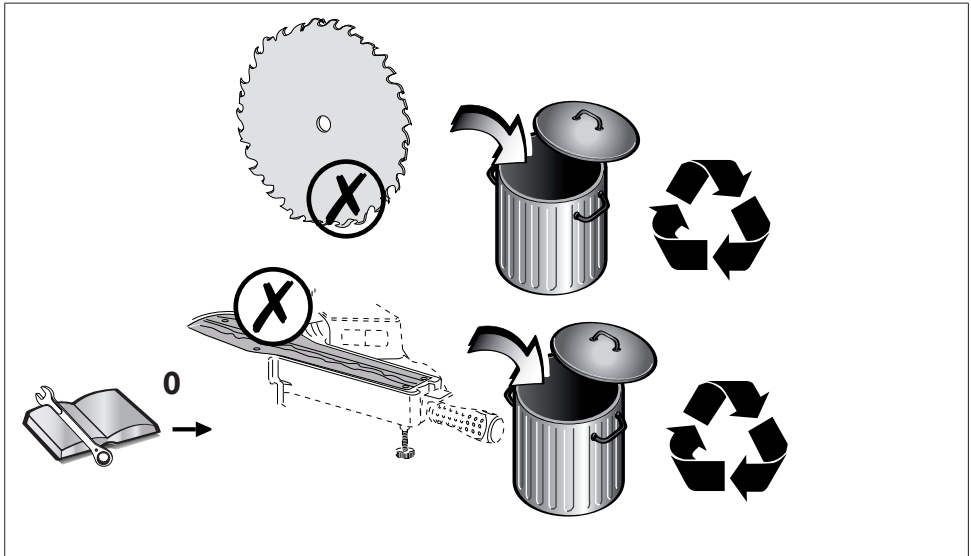





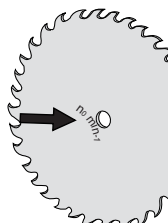

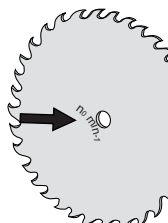
$n_0 \text{ min}^{-1}$ = / > 

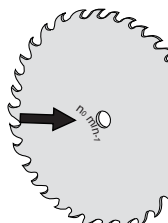







FF GROUP 

no: _____ kg

W _____ A Is. C.F.

FF GROUP TOOL INDUSTRIES Made in P.R.C. 

19300 ASPROPIYRGOS-GREECE   

TTMS 254 PLUS / TTMS 254i PLUS

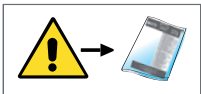
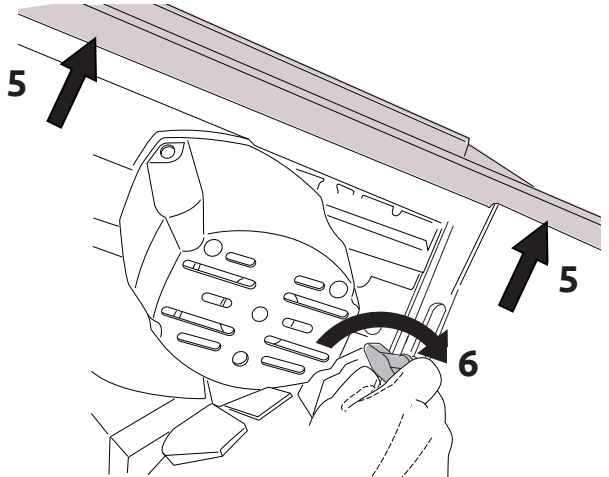
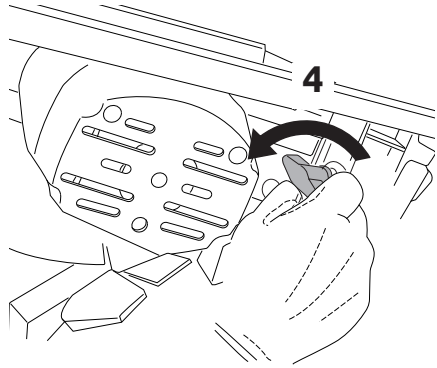
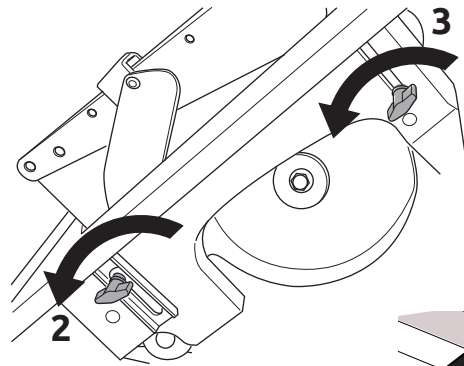
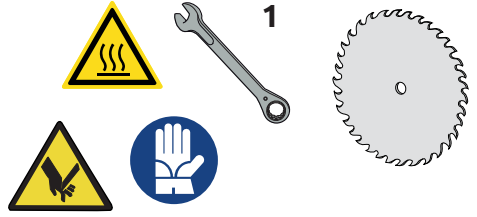
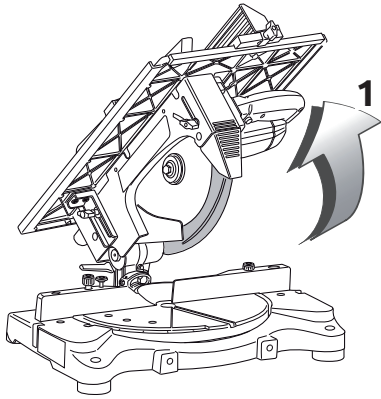

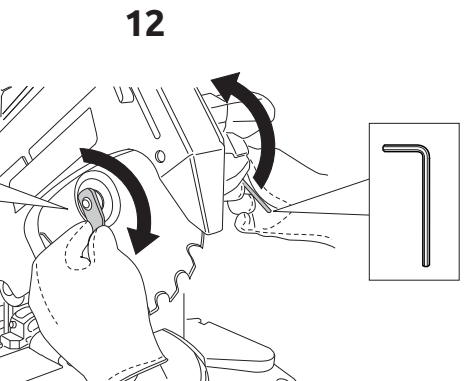
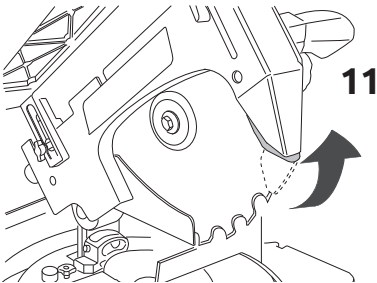
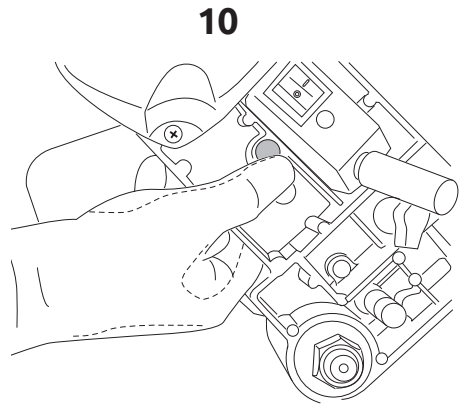
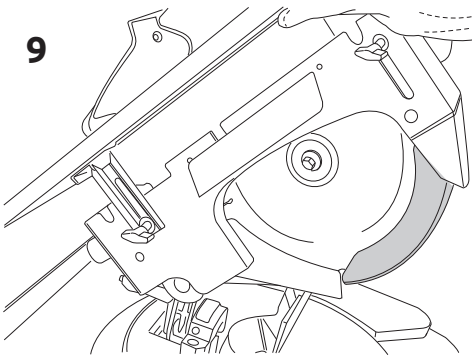
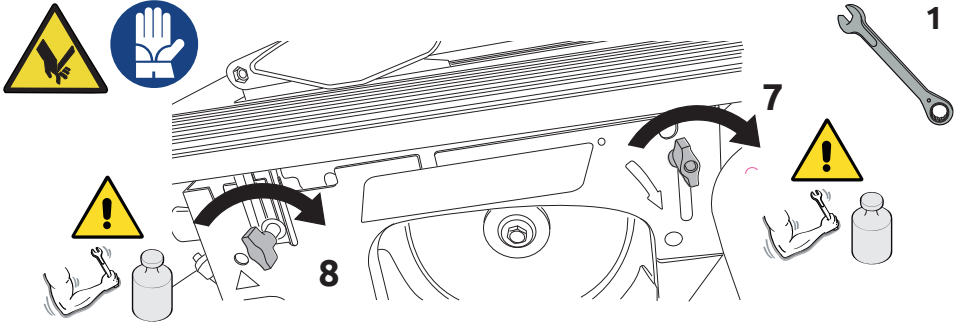

TTMS 254 PLUS / TTMS 254i PLUS

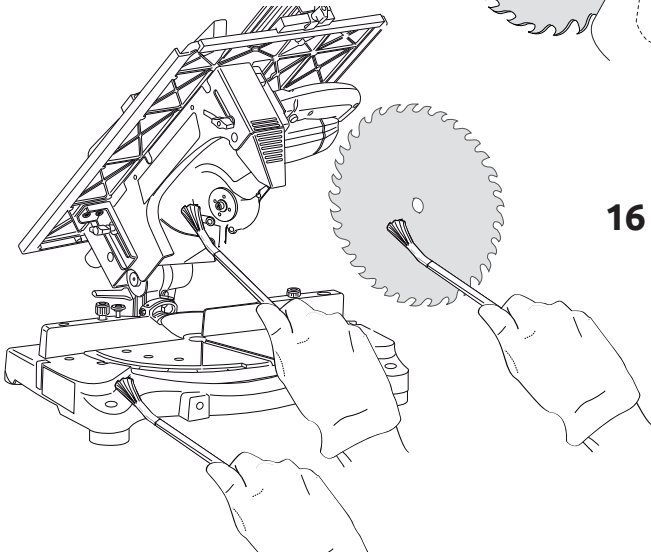
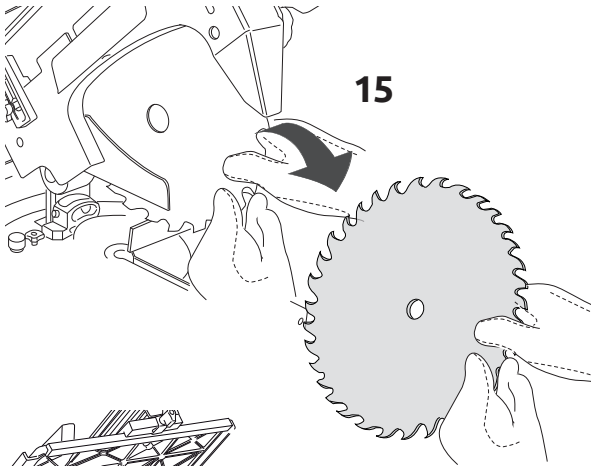
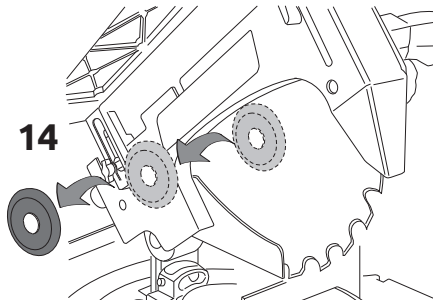
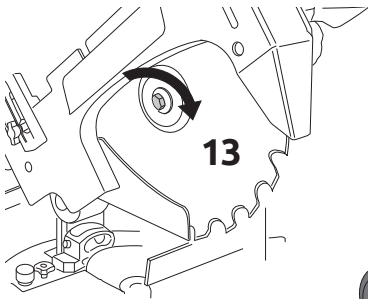

TTMS 254 PLUS / TTMS 254i PLUS

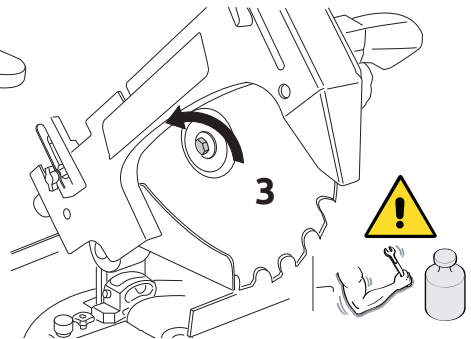
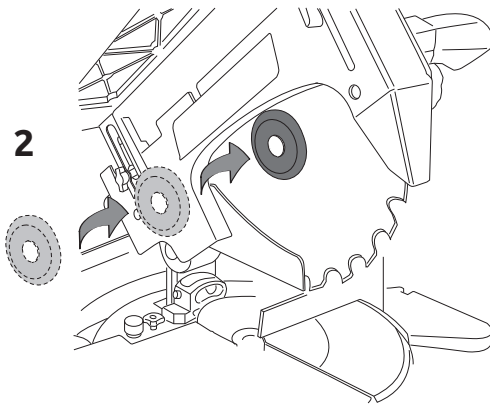
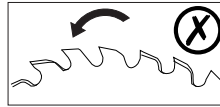
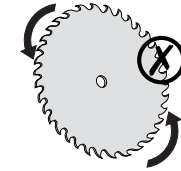
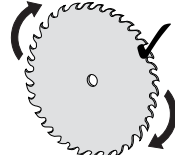
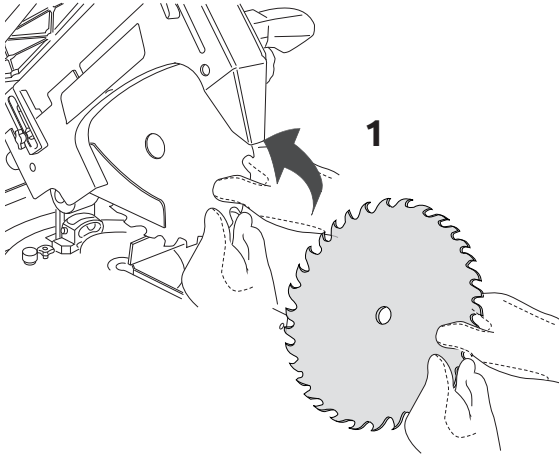
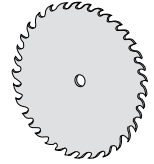

TTMS 254 PLUS / TTMS 254i PLUS

4

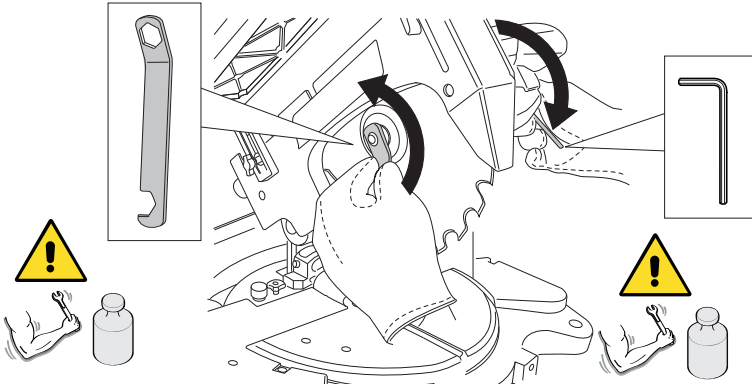

5

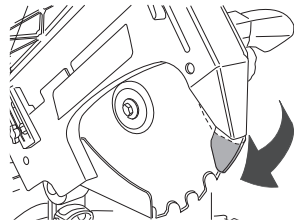
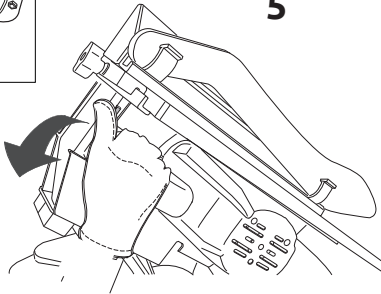
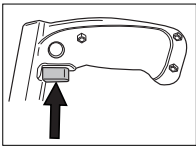

6

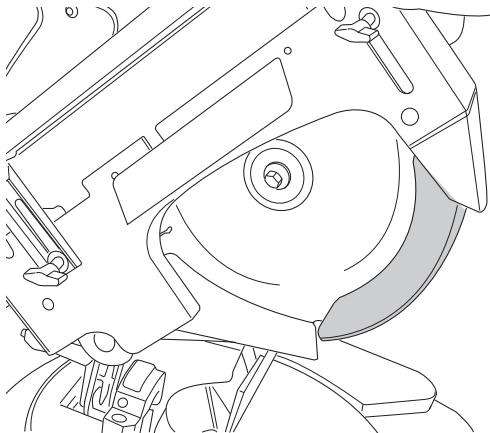



PRIMA DI ESEGUIRE QUALSIASI INTERVENTO DI MANUTENZIONE, FERMARE LA MACCHINA E FARLA RAFFREDDARE.



- Indossare i guanti di protezione.
- Indossare la protezione idonee per le vie respiratorie.
- Evitare di usare getti di aria compressa.

Quando necessario:

1. rimuovere con un aspiratore o con un pennello i trucioli residui di lavorazione intervenendo nella zona di taglio e sui piani di appoggio.
2. Smontare e pulire il filtro dell' aspiratore battendolo.

Ogni giorno:

1. rimuovere con un aspiratore o con un pennello i residui di lavorazione e le polveri dalla macchina, compreso il cavo di alimentazione.
2. Tenere sempre pulita la zona circostante la macchina, compresa la pavimentazione.

Una volta alla settimana:

scollegare il filtro o la condotta di scarico e pulire accuratamente l' aspiratore.



Ogni giorno:

1. Verificare l'integrità del cavo di alimentazione.
2. Verificare le integrità delle protezioni.
3. Verificare l' integrità e l'usura della lama.
4. Verificare che l'arresto della lama avvenga entro 10 secondi dal rilascio del pulsante.
5. Verificare che la molla del braccio permetta al braccio di risalire fino al fermo meccanico in un tempo massimo di 2 secondi.



BEFORE PERFORMING ANY MAINTENANCE WORK, STOP THE MACHINE AND LET IT COOL DOWN.



- Wear protective gloves.
- Wear suitable airway protection PPE.
- Avoid using jets of compressed air.

When necessary:

1. Remove any shavings or work residues from around the cutting zone and the work surfaces using a small brush or vacuum cleaner.
2. Disassemble the dust extractor filter and clean it by tapping it.

Every day:

1. Remove any work residues and dust from the machine, including the power cable, using a small brush or vacuum cleaner.
2. Always keep the work area around the machine, including the floor, clean and tidy.

Once a week:

Disconnect the exhaust filter or conduit and clean thoroughly with a vacuum cleaner.



Every day:

1. Check that the power cable is intact.
2. Check that all guards are intact.
3. Check that the blade is intact and shows no signs of wear.
4. Check that the blade stops within 10 seconds of the button being released.
5. Check that the arm spring allows the arm to go back up to the mechanical stopper within a maximum time of 2 seconds.

FR NETTOYAGE 

AVANT D'EFFECTUER TOUTE INTERVENTION D'ENTRETIEN, IL EST NÉCESSAIRE D'ARRÊTER LA MACHINE ET DE LA LAISSER REFROIDIR.



- Porter les gants de protection.
- Porter les dispositifs de protection appropriés pour les voies respiratoires.
- Éviter d'utiliser des jets d'air comprimé.

Au besoin :

1. éliminer, à l'aide d'un aspirateur ou d'un pinceau les copeaux d'usinage en intervenant dans la zone de coupe et sur les plans d'appui.
2. Déposer et nettoyer le filtre de l'aspirateur en le battant.

Tous les jours :

1. éliminer les résidus d'usinage et les poussières de la machine, y compris le câble d'alimentation, à l'aide d'un aspirateur ou d'un pinceau.
2. Maintenir toujours propre la zone autour de la machine, y compris le revêtement du sol.

Une fois par semaine :

déconnecter le filtre ou la conduite d'évacuation et nettoyer soigneusement l'aspirateur.

FR VÉRIFICATIONS **Tous les jours :**

1. Vérifier l'intégrité du câble d'alimentation.
2. Vérifier l'intégrité des protections.
3. Vérifier l'intégrité et l'état d'usure de la lame.
4. Vérifier l'effectif arrêt de la lame dans les 10 secondes après avoir relâché le bouton de marche.
5. Vérifier que le ressort du bras assure au bras de retourner en butée de l'arrêt mécanique dans un temps maximum de 2 secondes.

BG ПОЧИСТВАНЕ 

ПРЕДИ ДА ИЗВЪРШИТЕ КАКВАТО И ДА Е ОПЕРАЦИЯ ПО ПОДДРЪЖКА, СПРЕТЕ МАШИНАТА И Я ОСТАВЕТЕ ДА ИЗСТИНЕ.



- Носете защитни ръкавици.
- Носете подходящи защиты за дихателните пътища.
- Избягвайте използване на въздух под налягане.

Когато е необходимо:

1. отстранете с aspirator или четчица за остатъци от рязането при обработката като навлизате в зоната на рязане и на плата за поставяне.
2. Свалете и почистете филтъра на аспиратора като го изтупате.

Всеки ден:

1. отстранете с aspirator или четчица за остатъци от рязането при обработката от машината и захранващ кабел.
2. Пазете постоянно чиста зоната около машината, включително и пода.

Веднъж седмично:

свалете филтъра и тръбата за отвеждане и почистете добре аспиратора

BG ПРОВЕРКИ **Всеки ден:**

1. Проверете целостта на захранващия кабел.
2. Проверете целостта на защитата.
3. Проверете целостта и износването на острието.
4. Проверете дали спирането на острието става за време от 10 секунди от отпускане на бутона.
5. Проверете дали пружината на рамото го отпуска до механичният стоп за време най-много 2 секунди.

HR ČIŠĆENJE **PRIJE IZVOĐENJA BILO KOJEG POSTUPKA ODRŽAVANJA ZAUSTAVITE STROJ I PUSTITE GA DA SE OHLADI.**

- Nosite zaštitne rukavice.
- Nosite odgovarajuću zaštitu za dišne puteve.
- Izbjegavajte korištenje mlazova komprimiranog zraka.

Po potrebi:

1. pomoću usisavača ili četkom uklonite ostatke strugotina za obradu zahvaćajući u područje rezanja te na osloncima.
2. Demontirajte i očistite filter aspiratora.

Svaki dan:

1. pomoću usisavača ili četkom iz stroja uklonite radne ostatke i prašinu uključujući i kabel za napajanje.
2. Područje oko stroja mora uvijek čisto, uključujući i pod.

Jednom tjedno:

isključite filter ili odvodnu cijev i temeljito očistite usisavač.

HR PREGLED **Svaki dan:**

1. Provjerite cjelovitost kabela napajanja.
2. Provjerite cjelovitost zaštita.
3. Provjerite cjelovitost i istrošenost sječiva.
4. Provjerite pojavljuje li se blokada sječiva u roku od 10 sekundi od pritiska na gumb.
5. Provjerite omogućuje li opruga pomicanje ruke do mehaničkog zaustavljača u maksimalnom vremenu od 2 sekunde.

SR ČIŠĆENJE **PRE IZVRŠAVANJA BILO KOJE INTERVENCIJE ODRŽAVANJA, ZAUSTAVITI MAŠINU I PUSTITI JE DA SE OHLADI.**

- Nositi zaštitne rukavice.
- Nosite odgovarajuću zaštitu za disajne puteve.
- Izbjegavajte mlazeve komprimiranog vazduha.

U slučaju potrebe:

1. ukloniti aspiratorom ili četkicom preostale strugotine od obrade, u zoni za rezanje i podupirajućim površinama.
2. Izvadite i očistite filter aspiratora tako što ga otresete.

Svakog dana:

3. uklonite aspiratorom ili četkicom ostatke od obrade i prašinu iz mašine, uključujući kabl za napajanje.
4. Odžavajte uvek čistom zonu okolo mašine, uključujući površinu poda.

Jedanput sedmično:

odvojite filter i izdovnu cev i očistite pažljivo aspirator.

SR PROVERE **Svakog dana:**

1. Proverite ispravnost kabela za napajanje.
2. Proverite ispravnost zaštita.
3. Proverite ispravnost i pohabanost sečiva.
4. Proverite da li se zaustavljanje sečiva javlja u roku od 10 sekundi od puštanja prekidača.
5. Proverite da li opruga šipke omogućava mehanizmu da se vrati sve do mehaničkog zaustavljanja za maksimalno vreme od 2 sekunde.



ΠΡΙΝ ΑΠΟ ΚΑΘΕ ΣΥΝΤΗΡΗΣΗ, ΣΤΑΜΑΤΗΣΤΕ ΤΗ ΜΗΧΑΝΗ ΚΑΙ ΑΦΗΣΤΕ ΤΗΝ ΝΑ ΚΡΥΩΣΕΙ.



- Φορέστε γάντια προστασίας.
- Φορέστε κατάλληλη προστασία για τις αναπνευστικές οδούς.
- Αποφύγετε τη χρήση πεπιεσμένου αέρα.

Όταν χρειάζεται:

1. αφαιρέστε με έναν αναρροφητή ή με ένα πινέλο τα υπολείμματα επεξεργασίας παρεμβαίνοντας στην περιοχική κοπή και στις επιφάνειες στήριξης.
2. Αφαιρέστε και καθαρίστε το φίλτρο του αναρροφητή χτυπώντας το.

Κάθε μέρα:

1. αφαιρέστε με έναν αναρροφητή ή με ένα πινέλο τα υπολείμματα επεξεργασίας και τις σκόνης του μηχανήματος και του καλωδίου τροφοδοσίας.
2. Να κρατάτε πάντα καθαρή την γύρω περιοχή από το μηχάνημα, συμπεριλαμβανομένου και του δαπέδου.

Μία φορά την εβδομάδα:

αποσυνδέστε το φίλτρο ή τον αγωγό εκκένωσης και καθαρίστε με προσοχή τον αναρροφητή.



Κάθε μέρα:

1. Ελέγχετε την ακεραιότητα του καλωδίου τροφοδοσίας.
2. Ελέγχετε την ακεραιότητα των προστασιών.
3. Ελέγχετε την ακεραιότητα και τη φθορά της λεπίδας.
4. Βεβαιωθείτε ότι το σταμάτημα της λεπίδας γίνεται εντός 10 δευτερολέπτων από την απελευθέρωση του κουμπιού.
5. Βεβαιωθείτε ότι το ελατήριο του βραχίονα επιτρέπει στον βραχίονα να ανέβει μέχρι τον μηχανικό αναστολέα για μέγιστο χρόνο μέχρι 2 δευτερόλεπτα.



MIELŐTT BÁRMILYEN KARBANTARTÁSI MŰVELETET ELKEZDENE, ÁLLÍTS LE A GÉPET, ÉS VÁRJA MEG, HOGY KIHŰLJÖN.



- Viseljen védőkesztyűt.
- Viseljen megfelelő légzésvédőt.
- Lehetőség szerint ne használjon sűrített levegőt.

Szükség esetén:

1. elszívóberendezéssel vagy ecsettel távolítsa el a megmunkálás során keletkezett forgácsot a vágóterületről és a támasztófelületről.
2. Szerelje le, és ütögetve tisztítsa meg az elszívóberendezés szűrőjét.

Naponta:

1. elszívóberendezéssel vagy ecsettel távolítsa el a megmunkálás során keletkezett maradékokat és a port a gépről és a tápvezetékéről.
2. A gép környezetét, beleértve a padlót is, mindig tartsa tisztán.







Hetente egyszer:

kösse le a szűrőt vagy az elvezető csövet, és gondosan tisztítsa meg az elszívóberendezést.

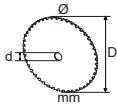

Naponta:

1. Ellenőrizze, hogy sértetlen-e a tápvezeték.
2. Ellenőrizze, hogy sértetlenek-e a védőburkolatok.
3. Ellenőrizze a fűrészlap sértetlenségét és kopását.
4. Ellenőrizze, hogy a nyomógomb felengedése után 10 másodpercen belül leálljon a fűrészlap.
5. Ellenőrizze, hogy a kar rugója lehetővé teszi-e, hogy a kar maximum 2 másodperc alatt visszatérjen a mechanikus ütközőhöz.

	 (W)	 (V/Hz)	 (n 1/min)	 (kg)		 ISO EN 3746
TTMS 254 PLUS	1550	230/50	4200	14,5	D254-d30	mm 40x40x2 L _{eq} 77,9 dB(A) L _{wa} 102,5 dB(A) K _{pA} 3 dB
TTMS 254i PLUS	1300		2850	17,5	EN 847-1	mm 40x40x2 L _{eq} 74,0 dB(A) L _{wa} 96,9 dB(A) K _{pA} 3 dB

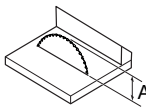
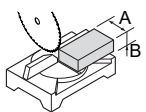
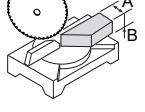
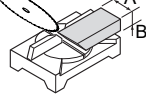
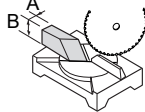
					
TTMS 254 PLUS	(A) 40	90° (mm)	45° DX - SX (mm)	45° SX (mm)	45° SX (mm)
TTMS 254i PLUS		(A)162 x (B)78	(A)112 x (B)60	(A)150x (B)53	(A)43 x (B)43
		(A)162 x (B)75	(A)112x (B)48	(A)150 x (B)53	(A)43 x (B)43

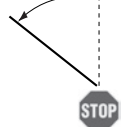
		
TTMS 254 PLUS	dx - sx - 47°	45°
TTMS 254i PLUS		



IT SCHEMA ELETTRICO (vedi allegato)

EN ELECTRICAL DIAGRAM (see annex)

FR SCHÉMA ÉLECTRIQUE (voir annexe)

BG ЕЛ. СХЕМА (вж. приложението)

HR PRIKAZ ELEKTRIČNIH INSTALACIJA (pogledati dodatak)

SR ELEKTRIČNI DIJAGRAM (videti prilog)

EL ΗΛΕΚΤΡΙΚΟ ΣΧΕΔΙΑΓΡΑΜΜΑ (δείτε επισύναψη)

RO SCHEMA ELECTRICĂ (a se vedea anexa)

HU ELEKTROMOS KAPCSOLÁSI RAJZ (lásd a mellékletet)

IT TAVOLE RICAMBI - Posizione (P) - Codice (C) Note (N) - (vedi allegato)

EN SPARE PARTS TABLE - Position (P) - Code (C) Notes (N) - (see annex)

FR PLANCHES PIÈCES DÉTACHÉES - Position (P) - Code (C) Notes (N) - (voir annexe)

BG ТАБЛИЦИ С РЕЗЕРВНИТЕ ЧАСТИ - Позиция (P) - Код (C) Забележки (N) - (вж. приложенията)

HR TABLICA ZAMJENSKIH DIJELOVA – Položaj (P) – Šifra (C) Napomena (N) – (pogledati dodatak)



SR TABELE REZERVNIH DELOVA - Položaj (P) - Kód (C) Napomena (N) - (videti prilog)

EL ΠΙΝΑΚΕΣ ΑΝΤΑΛΛΑΚΤΙΚΩΝ - Θέση (P) - Κωδικός (C) Σημειώσεις (N) - (δείτε επισύναψη)

RO TABELE PIESE DE SCHIMB - Poziție (P) - Cod (C) Note (N) - (a se vedea anexa)

HU PÓTALKATRÉSZEK TÁBLÁZATA - Rajzszám (P) - Cikkszám (C) Megjegyzés (N) - (lásd a mellékletet)





	VOLT - Hz 	
SR	220 - 50	http://www.iec.ch/worldplugs/map.htm
BG - HR - FR - GR - UK - IT - RO	230 - 50	
CY	240 - 50	

IT GUIDA ALLA LOCALIZZAZIONE DEI GUASTI

PROBLEMA / GUASTO	PROBABILE CAUSA	RIMEDIO SUGGERITO
Il motore non funziona	1. Motore, cavo rete o spina difettosi. 2. Fusibili bruciati. 3. Spazzole danneggiate (versione con motore a spazzole).	1. Fare controllare la macchina da personale specializzato;  PERICOLO - ATTENZIONE EVITARE ASSOLUTAMENTE DI RIPARARE DA SOLI IL MOTORE: POTREBBE ESSERE PERICOLOSO. 2. Controllare i fusibili e sostituirli se necessario. 3. Fare sostituire le spazzole da personale specializzato.
Il motore parte lentamente o non raggiunge la velocità di funzionamento	1. Bassa tensione di alimentazione 2. Avvolgimenti danneggiati.	1. Richiedere un controllo della tensione disponibile da parte dell'Ente erogatore. 2. Fare controllare il motore della macchina da personale specializzato.
Eccessivo rumore del motore	1. Motore difettoso. Avvolgimenti danneggiati.	1. Fare controllare il motore della macchina da personale specializzato.
Il motore non sviluppa la piena potenza	1. Circuiti dell'impianto rete sovraccaricati da luci, servizi o altri motori.	1. Evitare di utilizzare servizi o altri motori sullo stesso circuito al quale collegate la macchina.
Il motore tende a surriscaldarsi	1. Il motore è sovraccaricato 2. Raffreddamento del motore inadeguato.	1. Evitare di sovraccaricare il motore durante l'operazione di taglio. 2. Rimuovere la polvere dal motore per ottenere il corretto flusso dell'aria di refrigerazione.
Riduzione della capacità di taglio	1. La lama è stata affilata molte volte e si è ridotta di diametro.	1. Intervenire sulla regolazione del fine corsa della discesa della testa.
La finitura del taglio risulta grezza o ondulata	1. La lama è consumata oppure ha la dentatura inadatta allo spessore del materiale che si sta tagliando.	1. Fare affilare la lama da un centro di affilatura specializzato. 2. Verificare se la dentatura che si sta usando è giusta.
Scheggiatura del pezzo tagliato.	1. La dentatura della lama è inadatta al pezzo che si sta tagliando.	1. Verificare qual è la giusta dentatura da utilizzare.

EN TROUBLESHOOTING

PROBLEM / FAULT	PROBABLE CAUSE	SUGGESTED REMEDY
The motor is not working properly.	<ol style="list-style-type: none"> 1. Faulty motor, power cable or plug. 2. Blown fuses. 3. Damaged brushes (for version with brushed motor). 	<ol style="list-style-type: none"> 1. Have the machine checked by expert personnel.  DANGER - WARNING NEVER ATTEMPT TO REPAIR THE MOTOR YOURSELF: IT COULD BE DANGEROUS. 2. Check the fuses and replace them if necessary. 3. Have the brushes replaced by expert personnel.
The motor starts slowly or does not reach operating speed	<ol style="list-style-type: none"> 1. Low power supply voltage 2. Damaged windings. 	<ol style="list-style-type: none"> 1. Ask the power supply company to check how much voltage is available. 2. Have the machine motor checked by expert personnel.
The motor is making too much noise	<ol style="list-style-type: none"> 1. Faulty motor. Damaged windings. 	<ol style="list-style-type: none"> 1. Have the machine motor checked by expert personnel.
The motor does not reach full power	<ol style="list-style-type: none"> 1. Mains system circuits overloaded by lights, utilities or other motors. 	<ol style="list-style-type: none"> 1. Avoid using utilities or other motors on the same circuit to which the machine is connected.
The motor tends to overheat	<ol style="list-style-type: none"> 1. Motor overload 2. Insufficient motor cooling. 	<ol style="list-style-type: none"> 1. Avoid overloading the motor during cutting operations. 2. Remove the dust from the motor to achieve a correct flow of cooling air.
Reduction in cutting capacity	<ol style="list-style-type: none"> 1. The blade has been sharpened many times thus reducing its diameter. 	<ol style="list-style-type: none"> 1. Adjust the limit switch for head lowering.
The cutting finish is rough or uneven	<ol style="list-style-type: none"> 1. The blade is worn down or the teeth are not suitable for the thickness of the material being cut. 	<ol style="list-style-type: none"> 1. Have the blade sharpened by a specialized company. 2. Check the teeth on the blade are suitable.
Splintering of the cut workpiece.	<ol style="list-style-type: none"> 1. The blade's teeth are not suitable for the workpiece being cut. 	<ol style="list-style-type: none"> 1. Check the correct teeth to be used.

FR GUIDE DE LOCALISATION DES PANNES		
PROBLÈME/ PANNE	CAUSE PROBABLE	REMÈDE SUGGÉRÉ
Le moteur ne fonctionne pas.	<ol style="list-style-type: none"> 1. Moteur, câble de réseau ou fiche défectueux. 2. Fusibles brûlés. 3. Balais endommagés (version avec moteur à balais). 	<ol style="list-style-type: none"> 1. Faire contrôler la machine par un personnel spécialisé.  DANGER - ATTENTION ÉVITER ABSOLUMENT DE RÉPARER LE MOTEUR SANS AIDE : CETTE OPÉRATION POURRAIT ÊTRE DANGEREUSE. 2. Contrôler les fusibles et, le cas échéant, les remplacer. 3. Faire remplacer les balais par un personnel spécialisé.
Le moteur démarre lentement ou n'atteint pas la vitesse de fonctionnement	<ol style="list-style-type: none"> 1. Basse tension d'alimentation 2. Enroulements endommagés. 	<ol style="list-style-type: none"> 1. Demander un contrôle de la tension disponible de la part de l'Organisme de distribution. 2. Faire contrôler le moteur de la machine par un personnel spécialisé.
Niveau de bruit excessif du moteur.	<ol style="list-style-type: none"> 1. Moteur défectueux. Enroulements endommagés. 	<ol style="list-style-type: none"> 1. Faire contrôler le moteur de la machine par un personnel spécialisé.
Le moteur ne développe pas la pleine puissance.	<ol style="list-style-type: none"> 1. Circuits de l'installation de réseau surchargés par éclairages, services ou autres moteurs. 	<ol style="list-style-type: none"> 1. Éviter d'activer des services ou d'utiliser d'autres moteurs sur le même circuit auquel est reliée la machine.
Le moteur a tendance à se surchauffer.	<ol style="list-style-type: none"> 1. Le moteur est surchargé. 2. Refroidissement du moteur non approprié. 	<ol style="list-style-type: none"> 1. Éviter de surcharger le moteur pendant l'opération de coupe. 2. Éliminer la poussière du moteur afin d'assurer le correct flux d'air de réfrigération.
Réduction de la capacité de coupe	<ol style="list-style-type: none"> 1. La lame a été aiguisée plusieurs fois et le diamètre est donc réduit. 	<ol style="list-style-type: none"> 1. Intervenir sur le réglage du fin de course de la descente de la tête.
Le finissage de la coupe est brute ou ondulé.	<ol style="list-style-type: none"> 1. La lame est usée ou bien elle n'a pas la denture appropriée pour l'épaisseur du matériau à couper. 	<ol style="list-style-type: none"> 1. Faire aiguiser la lame par un centre d'affûtage spécialisé. 2. Vérifier que la denture utilisée soit appropriée à l'usage.
Ébrèchement de la pièce coupée.	<ol style="list-style-type: none"> 1. La denture de la lame n'est pas appropriée pour le matériau à couper. 	<ol style="list-style-type: none"> 1. Vérifier quelle est la denture appropriée à utiliser.

BG НАСОКИ ЗА НАМИРАНЕ НА ПОВРЕДИ

ПРОБЛЕМ / ПОВРЕДА	ВЕРОЯТНА ПРИЧИНА	ПРЕПОРЪЧАНО РЕШЕНИЕ
Двигателят не работи	<ol style="list-style-type: none"> 1. Дефектен двигател, мрежов кабел или щепсел. 2. Изгорели предпазители. 3. Повредени четки (модел с четков двигател). 	<ol style="list-style-type: none"> 1. Машината трябва да се провери от специализиран персонал; ⚠ ОПАСНОСТ - ВНИМАНИЕ! ТРЯБВА АБСОЛЮТНО ДА СЕ ИЗБЯГВА САМОСТОЯТЕЛНИЯ РЕМОТ НА ДВИГАТЕЛЯ: ТОВА МОЖЕ ДА Е ОПАСНО. 2. Проверете предпазителите и ги заменете, ако е необходимо. 3. Сменете четките от специализиран персонал;
Двигателят тръгва бавно или не достига работната скорост	<ol style="list-style-type: none"> 1. Ниско захранващо напрежение 2. Повредени намотки. 	<ol style="list-style-type: none"> 1. Изисквайте проверка на наличното напрежение от страна на организацията доставчик. 2. Двигателят на машината трябва да се провери от специализиран персонал.
Прекален шум от двигателя	<ol style="list-style-type: none"> 1. Дефектен двигател. Повредени намотки. 	<ol style="list-style-type: none"> 1. Двигателят на машината трябва да се провери от специализиран персонал.
Двигателят не достига пълна мощност	<ol style="list-style-type: none"> 1. Веригите в захранващата инсталация са претоварени поради лампи, обслужващи вериги или други двигатели. 	<ol style="list-style-type: none"> 1. Избягвайте да използвате други консуматори или други двигатели в същата верига, към която е свързана машината.
Двигателят прегрява	<ol style="list-style-type: none"> 1. Двигателят е подложен на прекалено натоварване 2. Недобро охлаждане на двигателя. 	<ol style="list-style-type: none"> 1. Избягвайте да претоварвате двигателя по време на операцията по рязане. 2. Отстранете праха от двигателя за постигане добър поток на въздуха за охлаждане.
Намаляване капацитета на рязане	<ol style="list-style-type: none"> 1. Ножа е точен многократно и диаметърът е намален. 	<ol style="list-style-type: none"> 1. Действайте на регулатор стопер спускане глава.
Обработката на детайла е груба или неравна	<ol style="list-style-type: none"> 1. Ножът е износен или зъбците не са подходящи за дебелината на материала, който се реже. 	<ol style="list-style-type: none"> 1. Наточете ножа в специализиран център за точене. 2. Проверете дали използваните зъбци са подходящи.
Трошене на парчето за рязане.	<ol style="list-style-type: none"> 1. Зъбците на ножа не са подходящи за парчето, което се реже. 	<ol style="list-style-type: none"> 1. Проверет, кои са подходящите зъбци за използване.

HR VODIČ ZA RJEŠAVANJE PROBLEMA		
PROBLEM / KVAR	MOGUĆI UZROK	PREDLOŽENO RJEŠENJE
Motor ne radi	<ol style="list-style-type: none"> 1. Pokvaren motor, mrežni kabel ili utikač. 2. Osigurači su pregorjeli. 3. Oštećene četke (verzija s motorem na četke). 	<ol style="list-style-type: none"> 1. Stroj mora provjeriti specijalizirano osoblje;  OPASNOST - POZOR NI U KOJEM SLUČAJU NE SMIJETE SAMI POPRAVLJATI MOTOR: POPRAVAK MOŽE BITI OPASAN. 2. Provjerite osigurače i zamijenite ih ako je potrebno. 3. Četke mora provjeriti specijalizirano osoblje.
Motor se pokreće polako ili ne dostiže radnu brzinu	<ol style="list-style-type: none"> 1. Nizak napon napajanja 2. Oštećeni namoti. 	<ol style="list-style-type: none"> 1. Zahtjev za kontrolom napetosti izvršavaju komunalne institucije. 2. Motor mora biti provjeren od strane specijaliziranog osoblja.
Prevelika buka motora	<ol style="list-style-type: none"> 1. Neispravan motor. Oštećeni namoti. 	<ol style="list-style-type: none"> 1. Motor mora biti provjeren od strane specijaliziranog osoblja.
Motor ne razvija punu snagu	<ol style="list-style-type: none"> 1. Kola sustava mreže su preopterećeni svjetlima, servisima ili drugim motorima. 	<ol style="list-style-type: none"> 1. Izbjegavate koristiti servise ili druge motore na istom sustavu na koji je povezan stroj.
Motor se pregrijava	<ol style="list-style-type: none"> 1. Motor je preopterećen 2. Neadekvatno hlađenje motora. 	<ol style="list-style-type: none"> 1. Izbjegavajte opterećivati motor za vrijeme rezanja. 2. Uklonite prašinu iz motora kako biste postigli ispravan protok zraka za hlađenje.
Smanjivanje kapaciteta za rezanje	<ol style="list-style-type: none"> 1. Sječivo je izoštreno mnogo puta i smanjeno u promjeru. 	<ol style="list-style-type: none"> 1. Intervenirajući na reguliranje krajnjeg zaustavljanja spuštanja glave.
Grub i valovit rez	<ol style="list-style-type: none"> 1. Sječivo je istrošeno ili njegovi zupci nisu prilagođeni debljini materijala koji se reže. 	<ol style="list-style-type: none"> 1. Sječivo dajte na oštrenje u specijalizirani centar. 2. Provjerite ispravnost korištenih zubaca.
Cijepanje odrezanog komada.	<ol style="list-style-type: none"> 1. Zupci sječiva neprikladni su za komad koji se reže. 	<ol style="list-style-type: none"> 1. Provjerite ispravnu nazubljenost za korištenje.

ΕΛ ΟΔΗΓΟΣ ΕΝΤΟΠΙΣΜΟΥ ΤΩΝ ΒΛΑΒΩΝ

ΠΡΟΒΛΗΜΑ / ΒΛΑΒΗ	ΠΙΘΑΝΗ ΑΙΤΙΑ	ΠΡΟΤΕΙΝΟΜΕΝΗ ΛΥΣΗ
Ο κινητήρας δεν λειτουργεί	<ol style="list-style-type: none"> 1. Ο κινητήρας, το καλώδιο δικτύου ή το βύσμα είναι ελαττωματικά. 2. Καμένες ασφάλειες. 3. Βούρτσες που έχουν υποστεί βλάβη (έκδοση κινητήρα με βούρτσες) 	<ol style="list-style-type: none"> 1. Ζητήστε έλεγχο της μηχανής από εξειδικευμένο προσωπικό  ΚΙΝΔΥΝΟΣ - ΠΡΟΣΟΧΗ ΑΠΟΦΥΓΕΤΕ ΤΗΝ ΕΠΙΔΙΟΡΩΣΗ ΤΟΥ ΚΙΝΗΤΗΡΑ ΜΟΝΟΙ ΣΑΣ· ΜΠΟΡΕΙ ΝΑ ΕΙΝΑΙ ΕΠΙΚΙΝΔΥΝΟ. 2. Ελέγξτε τις ασφάλειες και αντικαταστήστε τις αν είναι απαραίτητο. 3. Ζητήστε αντικατάσταση των βουρτσών από εξειδικευμένο προσωπικό.
Ο κινητήρας ξεκινά αργά ή δεν φθάνει την ταχύτητα λειτουργίας	<ol style="list-style-type: none"> 1. Χαμηλή τάση τροφοδοσίας 2. Κατεστραμμένες περιελίξεις 	<ol style="list-style-type: none"> 1. Ζητήστε έλεγχο της διαθέσιμης τάσης από τον Φορέα παροχής. 2. Ελέγξτε τον κινητήρα της μηχανής από εξειδικευμένο προσωπικό.
Υπερβολικός θόρυβος του κινητήρα	<ol style="list-style-type: none"> 1. Ελαττωματικός κινητήρας. Κατεστραμμένες περιελίξεις 	<ol style="list-style-type: none"> 1. Ελέγξτε τον κινητήρα της μηχανής από εξειδικευμένο προσωπικό.
Ο κινητήρας δεν αναπτύσσει πλήρη ισχύ	<ol style="list-style-type: none"> 1. Κυκλώματα του δικτύου υπερφορτωμένα από φώτα, υπηρεσίες ή άλλες μηχανές. 	<ol style="list-style-type: none"> 1. Αποφύγετε τη χρήση των υπηρεσιών ή άλλων μηχανών στο ίδιο κύκλωμα με το οποίο συνδέεται το μηχάνημα.
Ο κινητήρας τείνει να υπερθερμανθεί	<ol style="list-style-type: none"> 1. Ο κινητήρας έχει υπερφορτωθεί 2. Ακατάλληλη ψύξη του κινητήρα. 	<ol style="list-style-type: none"> 1. Αποφύγετε την υπερφόρτωση του κινητήρα κατά τη λειτουργία κοπής. 2. Αφαιρέστε τη σκόνη από τον κινητήρα για να έχετε σωστή ροή αέρα ψύξης.
Μείωση της ικανότητας κοπής	<ol style="list-style-type: none"> 1. Η λεπίδα έχει ακονιστεί πολλές φορές και έχει μειωμένη διάμετρο. 	<ol style="list-style-type: none"> 1. Ρυθμίστε τον αναστολέα καθόδου της κεφαλής.
Το φινίρισμα της κοπής είναι χονδροειδής ή οντουλέ	<ol style="list-style-type: none"> 1. Η λεπίδα έχει φθαρεί ή έχει ακατάλληλη οδόντωση για το πάχος του τεμαχίου που κόβετε. 	<ol style="list-style-type: none"> 1. Ακονίστε τη λεπίδα δε ένα ειδικευμένο κέντρο ακονίσματος. 2. Βεβαιωθείτε ότι η οδόντωση που χρησιμοποιείται είναι σωστή.
Αποκοπή του κομμένου τεμαχίου.	<ol style="list-style-type: none"> 1. Η οδόντωση της λεπίδας είναι ακατάλληλη για το τεμάχιο που κόβετε. 	<ol style="list-style-type: none"> 1. Βεβαιωθείτε για τη σωστή οδόντωση που πρέπει να χρησιμοποιήσετε.

RO GHID REFERITOR LA LOCALIZAREA DEFECTIUNILOR

PROBLEMĂ / DEFECTIUNE	CAUZA PROBABILĂ	REMEDIU SUGERAT
Motorul nu funcționează	<ol style="list-style-type: none"> 1. Motorul, cablul sau priza prezintă defecțiuni. 2. Siguranțe arse. 3. Perii deteriorate (versiune cu motor cu perii). 	<ol style="list-style-type: none"> 1. Solicitați verificarea mașinii de către personal specializat;  PERICOL - ATENȚIE NU REPARAȚI SINGURI MOTORUL: ȚĂR PUTEA FI FOARTE PERICULOS. 2. Controlați siguranțele și înlocuiți-le dacă este necesar. 3. Procedați la înlocuirea perilor de către personal calificat.
Motorul pornește lent sau nu atinge viteza de funcționare	<ol style="list-style-type: none"> 1. Tensiune de alimentare redusă 2. Înfășurări deteriorate. 	<ol style="list-style-type: none"> 1. Solicitați un control al tensiunii disponibile, din partea Instituției furnizoare. 2. Solicitați verificarea motorului mașinii de către personal specializat.
Zgomot excesiv al motorului.	<ol style="list-style-type: none"> 1. Motor defect. Înfășurări deteriorate. 	<ol style="list-style-type: none"> 1. Solicitați verificarea motorului mașinii de către personal specializat.
Motorul nu funcționează cu putere deplină.	<ol style="list-style-type: none"> 1. Circuitele rețelei supraîncărcate cu lumini, servicii sau alte motoare. 	<ol style="list-style-type: none"> 1. Evitați utilizarea serviciilor sau a altor motoare pe același circuit la care este conectat aparatul.
Motorul tinde să se supraîncălzească.	<ol style="list-style-type: none"> 1. Motorul este supraîncărcat 2. Răcire neadecvată a motorului. 	<ol style="list-style-type: none"> 1. Evitați supraîncărcarea motorului în timpul operației de tăiere. 2. Îndepărtați praful de la motor pentru a obține fluxul corect al aerului de refrigerare.
Reducerea capacității de tăiere	<ol style="list-style-type: none"> 1. Lama a fost ascuțită de multe ori și are diametrul redus. 	<ol style="list-style-type: none"> 1. Intervenți asupra reglării limitatorului de cursă a coborârii capului.
Finisajul tăieturii este grosier și ondulat	<ol style="list-style-type: none"> 1. Lama este uzată sau are dantura cu grosimea neadecvată pentru materialul care urmează a fi tăiat. 	<ol style="list-style-type: none"> 1. Procedați la ascuțirea lamei de către o ascuțitoare specializată. 2. Verificați dacă dantura utilizată este cea corectă.
Ciobirea piesei tăiate.	<ol style="list-style-type: none"> 1. Dantura lamei nu este adecvată pentru piesa care urmează a fi tăiată. 	<ol style="list-style-type: none"> 1. Verificați care este dantura corectă de utilizat.

HU ÚTMUTATÓ HIBAKERESÉSHEZ		
PROBLÉMA / MEGHIBÁSODÁS	VALÓSZÍNŰ KIVÁLTÓ OK	JAVASOLT MEGOLDÁS
A motor nem működik	<ol style="list-style-type: none"> 1. Meghibásodott a motor, a hálózati kábel vagy a csatlakozó. 2. Kiégett biztosítékok. 3. A szénkefék megsérültek (szénkefés motor esetén). 	<ol style="list-style-type: none"> 1. Ellenőriztesse a gépet szakemberrel;  FIGYELEM! VESZÉLY! SOHA NE JAVÍTSA SAJÁT MAGA A MOTOROT: VESZÉLYES LEHET. 2. Ellenőrizze az olvadóbiztosítókat és szükség esetén cserélje ki. 3. A szénkefákat szakemberrel cseréltesse ki.
A motor lassan indul vagy nem éri el az üzemi sebességet	<ol style="list-style-type: none"> 1. A tápfeszültség alacsony. 2. A tekercsek megsérültek. 	<ol style="list-style-type: none"> 1. Kérje az áramszolgáltatót, hogy ellenőrizze a rendelkezésre álló feszültséget. 2. Ellenőriztesse a gép motorját szakemberrel.
A motor nagyon hangos	<ol style="list-style-type: none"> 1. A motor meghibásodott. A tekercsek megsérültek. 	<ol style="list-style-type: none"> 1. Ellenőriztesse a gép motorját szakemberrel.
A motor nem működik teljes hatásfokkal	<ol style="list-style-type: none"> 1. A hálózati berendezés áramkörei túl vannak terhelve világítás, további szolgáltatások vagy más motorok által. 	<ol style="list-style-type: none"> 1. Ne használjon más szolgáltatásokat vagy motorokat ugyanarról az áramkőről, amelyre a készüléket csatlakoztatja.
A motor túlmelegszik	<ol style="list-style-type: none"> 1. A motor túl van terhelve 2. A motor hűtése nem megfelelő. 	<ol style="list-style-type: none"> 1. Ne terhelje túl a motort a vágási művelet során. 2. Távolítsa el a port a motorról, hogy a hűtőlevegő megfelelően tudjon áramlani.
Vágóképesség csökkenése	<ol style="list-style-type: none"> 1. A fűrészlap sokszor volt élvezve, átmérője csökkent. 	<ol style="list-style-type: none"> 1. Állítson a vágófej lemeneti végálláskapcsolóján.
A vágás sorjás vagy hullámos	<ol style="list-style-type: none"> 1. A fűrészlap kopott vagy a fogazása nem felel meg az elvágandó anyag vastagságának. 	<ol style="list-style-type: none"> 1. Éleztesse meg a fűrészlapot szakszervizben. 2. Ellenőrizze, hogy a használt fűrészlap fogazata megfelelő-e.
A levágott darab töredezik.	<ol style="list-style-type: none"> 1. A fűrészlap fogazata nem felel meg a munkadarabnak. 	<ol style="list-style-type: none"> 1. Ellenőrizze, hogy melyik a megfelelő fogazat.

IT DICHIARAZIONE DI CONFORMITÀ

TRONCATRICE DA TAVOLO
secondo la Direttiva Europea 2006/42/CE Allegato II.A
FEMI S.p.A. - Via Del Lavoro, 4 - 40023 Castel Guelfo - (BO) ITALIA

Dichiara sotto la propria esclusiva responsabilità che questa macchina è conforme alle disposizioni della Direttiva Macchine **2006/42/CE** ed è identica, in quanto inclusa nell' allegato IV della direttiva, al macchinario oggetto della certificazione CE di tipo (vedi etichetta riportata) rilasciata da ICE Istituto Certificazione Europea SpA, organismo notificato n. 0303. E' inoltre conforme alle disposizioni delle seguenti altre direttive: **2014/30/UE, 2014/35/UE, 2011/65/UE, 2012/19/UE.**

EN DECLARATION OF CONFORMITY

TABLE TOP MITRE SAW
in compliance with European Directive 2006/42/EC Annex II.A
FEMI S.p.A. - Via Del Lavoro, 4 - 40023 Castel Guelfo - (BO) ITALIA

Hereby declares under its sole responsibility that this machine conforms to the regulations indicated in Machinery Directive **2006/42/EC** and is identical, as far as it is included in Annex IV of the Directive, to machinery subject to CE-type certification (see the label shown) issued by the ECI European Certification Institute Ltd., notified body no. 0303. Furthermore it conforms to the following directives: **2014/30/UE, 2014/35/UE, 2011/65/UE, 2012/19/UE.**

BG ДЕКЛАРАЦИЯ ЗА СЪОТВЕТСТВИЕ

КОМБИНИРАН ЦИРКУЛЯР
съгласно Европейска директива 2006/42/ЕО Приложение II.A
FEMI S.p.A. - Via Del Lavoro, 4 - 40023 Castel Guelfo - (BO) ITALIA

Декларира на своя отговорност, че тази машина отговаря на разпоредбите на Директива машини **2006/42/CE** и е идентична, съгласно посоченото в приложение IV на директивата, на машина предмет на CE сертификат от вида (вижте посоченият етикет) издаден от ICE Институт за Европейско Сертифициране С.п.А., нотифициращ орган organismo notificato № 0303. Отговаря на разпоредбите и на следните допълнителни директиви: **2014/30/EC, 2014/35/EC, 2011/65/EC, 2012/19/EC.**

Persona autorizzata a costituire il fascicolo tecnico:
The person authorized to draw up the technical file:
Person, die bevollmächtigt ist, die technischen Unterlagen zusammenstellen
Personne autorisée à constituer le dossier technique:
Persona autorizada a elaborar el documento técnico:
Pessoa autorizada a compilar o processo técnico:

MAURIZIO CASANOVA
Presso - At - Bei - Auprès de - En - Junto da:

FR DÉCLARATION DE CONFORMITÉ

SCIE À ONGLETS DE TABLE
selon la Directive Européenne 2006/42/CE Annexe II.A
FEMI S.p.A. - Via Del Lavoro, 4 - 40023 Castel Guelfo - (BO) ITALIA

Déclare sous sa propre responsabilité exclusive que cette machine est conforme aux dispositions de la Directive Machines **2006/42/CE** et qu'elle est identique, étant incluse dans l'annexe IV de la directive, à la machine objet de la certification CE de type (voir étiquette reportée) délivrée par l'ICE Institut de Certification Européenne SpA, organisme certifié n. 0303. Elle est en outre conforme aux dispositions des autres directives suivantes: **2014/30/UE, 2014/35/UE, 2011/65/UE, 2012/19/UE.**

HR OZNAKA SUKLADNOSTI

KOMBINIRANA PREKLOPNA PILA
sukladno Europskoj direktivi br. 2006/42/EZ Priloga II A
FEMI S.p.A. - Via Del Lavoro, 4 - 40 023 Castel Guelfo - (BO) ITALIA

Izjavljuje pod isključivom odgovornošću da je ovaj stroj u skladu s Direktivom **2006/42/EC** te je identičan, kako je to uključeno u dodatku IV Direktive, stroju certifikata EZ (vidi etiketu) kojeg izdaje ICE Istitutu Certificazione Europea SpA, prijavljeno tijelo br. 0303. Također je u skladu sa sljedećim direktivama: **2014/30/UE, 2014/35/UE, 2011/65/UE, 2012/19/UE.**

SR DEKLARACIJA O USKLAĐENOSTI

POTEZNA TESTERA SA STOLOM
prema Evropskoj direktivi 2006/42 / EC Aneks II.A
FEMI S.p.A. - Via Del Lavoro, 4 - 40023 Castel Guelfo - (BO) ITALIA

Izjavljuje se pod punom odgovornošću da je ova mašina je u skladu sa Direktivom za Mašine **2006/42/EC** i identična je, kao što je obuhvaćeno Aneksom IV Direktive, mašini koja je dobila oznaku CE (pogledajte etiketu) izdata od strane ICE Evropskog instituta za sertifikaciju SpA, obavešteni organ br. 0303. Takođe je u skladu sa sledećim ostalim direktivama: **2014/30/UE, 2014/35/UE, 2011/65/UE, 2012/19/UE.**

FEMI SpA Via del Lavoro, 4 - 40023 Castel Guelfo - (BO) ITALY.
Riferimento norme armonizzate/Reference to harmonized standards/Bezug auf harmonisierte Normen/ Référence des normes harmonisées/ Referencia a las normas armonizadas/ Referência às normas harmonizadas
EN ISO 12100
EN 61029-2-11
EN 55014-1, EN 55014-2



Castel Guelfo (BO) Italy 20/04/2016

FEMI S.p.A.
Il Presidente del Consiglio
Maurizio Casanova

EL

ΔΗΛΩΣΗ ΣΥΜΜΟΡΦΩΣΗΣ

ΣΥΝΔΥΑΣΤΙΚΗ ΜΗΧΑΝΗ ΚΟΠΗΣ

σύμφωνα με την Ευρωπαϊκή Οδηγία 2006/42 / ΕΚ παράρτημα II Α
FEMI S.p.A. - Via Del Lavoro, 4 - 40023 Castel Guelfo - (BO) ITALIA

Δηλώνει υπό την αποκλειστική ευθύνη της ότι το παρόν μηχανήναμ συμμορφώνεται με τις διατάξεις της Οδηγία περί Μηχανών **2006/42/CE** και είναι πανομοιότυπο με ό,τι συμπεριλαμβάνεται στον παράρτημα IV της οδηγίας του εν λόγω μηχανήματος που αποτελεί αντικείμενο πιστοποίηση CE τύπου (δείτε ετικέτα που αναφέρεται) και έχει παραχωρηθεί από το ινστιτούτο ICE Certificazione Europea SpA, κοινοποιημένος οργανισμός αρ. 0303. Συμμορφώνεται, επίσης, με τις διατάξεις των ακόλουθων οδηγιών: **2014/30/UE, 2014/35/UE, 2011/65/UE, 2012/19/UE.**

RO

DECLARAȚIE DE CONFORMITATE

MAȘINĂ DE TĂIAT COMBINATĂ

Potrivit Directivei Europene 2006/42/CE Anexa II.A
FEMI S.p.A. - Via Del Lavoro, 4 - 40023 Castel Guelfo - (BO) ITALIA

Declară pe propria răspundere că această mașină este în conformitate cu Directiva **2006/42/CE** și este identică, așa cum este inclus în Anexa IV a Directivei, cu echipamentul care face obiectul certificării CE de tip (consultați eticheta) emisă de ICE Institutul European de Certificare SpA, organism notificat sub nr. 0303. Este de asemenea, în conformitate cu dispozițiile Directivelor următoare: **2014/30/UE, 2014/35/UE, 2011/65/UE, 2012/19/UE.**

HU

MEGFELELŐSÉGI NYILATKOZAT

KOMBINÁLT GÉRVÁGÓ

a 2006/42/EK európai irányelv II.A melléklete szerint
a FEMI S.p.A. - Via Del Lavoro, 4 - 40023 Castel Guelfo - (BO) ITALIA

Kizárólagos felelőssége tudatában kijelenti, hogy a gép megfelel a **2006/42/EK** Gépekről szóló irányelvnek, és megegyezik, mivel az irányelv IV. Fejezete tartalmazza, az ICE Istituto di Certificazione Europea SpA, 0303 sz. akkreditált testület által kiállított EK-típusánusítvány tárgyát képező géppel (lásd a csatolt címkét). Ezen túl megfelel a következő további irányelveknek: **2014/30/EU, 2014/35/EU, 2011/65/EU, 2012/19/EU.**

Persona autorizzata a costituire il fascicolo tecnico:
 Person geautoriseerd voor het opstellen van het technisch dossier:
 Teknisen asiakirjan laatimista varten valtuutettu henkilö
 Person med tilladelse til at udforme det tekniske dossier:
 Behørigt att upprätta den tekniska dokumentationen:
 Person som er autoriseret til å utforme teknisk hefte:

MAURIZIO CASANOVA

Presso – Bij - Paikka - C/O - Vid - Hos:
FEMI SpA Via del Lavoro, 4 - 40023 Castel Guelfo - (BO) ITALY.

Riferimento norme armonizzate/Referentie aan geharmoniseerde normen/Viittaus yhdenmukaistettuihin standardeihin/Henvísning til harmoniserede standarder/Hänvisning till harmoniserade standarder/Harmoniserede referansnormer

EN ISO 12100
 EN 61029-2-11
 EN 55014-1, EN 55014-2

CE

Castel Guelfo (BO) Italy 20/04/2016

FEMI S.p.A.

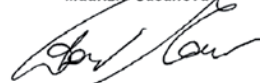
Il Presidente del Consiglio
 Maurizio Casanova





QUALITY POWER TOOLS

FF Group Tool Industries



9,5 Km Attiki Odos, Aspropyrgos

19300, Athens, Greece



+30 210 55 98 400



info@ffgroup-toolindustries.com



www.ffgroup-tools.com