

BORMANN®



BPC6000

023500



v2.2



WWW.NIKOLAOUTOOLS.GR

2 YEARS
WARRANTY

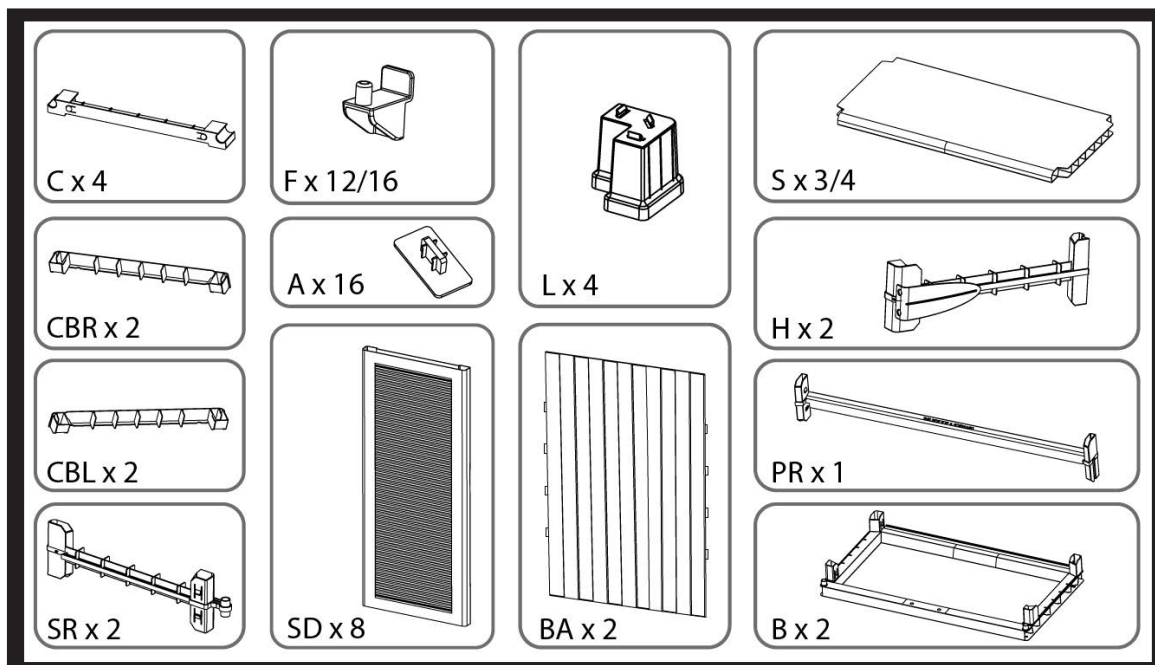

EN

Utility cabinet

Assembly instructions: To avoid suffocation, keep small parts away from children. Please keep the instruction manual for future reference. Please follow the assembly instructions step-by-step and identify each component by the mark it carries before using it. Maximum weight limit for each shelf must not be exceeded. Weight must be evenly distributed on each shelf. For maximum stability, assemble the cabinet without legs. The cabinet must be attached to a wall. Do not hang goods on the door or put objects on the edge of the top panel. Accessories for attaching the cabinet to the wall are not included.

IT

Armadio di servizio

Istruzioni di Montaggio: Tenere le parti piccole fuori della portata dei bambini per evitare possibili soffocamenti. Conservare il manuale d'istruzioni per riferimento futuro. Seguire le istruzioni di montaggio passo a passo e identificare ogni parte tramite la propria etichetta, prima dell'uso. Non superare il limite di peso per ogni scaffale. Distribuire uniformemente il peso sullo scaffale. Per una massima stabilità, assemblare l'armadio senza piedini. L'armadio deve essere fissato al muro. Non appendere oggetti all'anta, né mettere oggetti sul bordo del pannello superiore. Gli accessori per il fissaggio al muro non sono inclusi.

BG

Шкаф за съхранение

Инструкции за сглобяване: За да избегнете задушаване, дръжте малките части далеч от деца. Моля, запазете ръководството за употреба за бъдещи справки. Моля, следвайте инструкциите за сглобяване стъпка по стъпка и идентифицирайте всеки компонент по маркировката, която носи, преди да го използвате. Не трябва да се превишава максималното тегло за всеки рафт. Теглото трябва да се разпределя равномерно върху всеки рафт. За максимална стабилност сглобявайте шкафа без крачета. Шкафът трябва да бъде прикрепен към стена. Не закачайте стоки на вратата и не поставяйте предмети върху ръба на горния панел. Аксесоарите за закрепване на шкафа към стената не са включени в комплекта.

RO

Dulap de depozitare

Instrucțiuni de asamblare: Pentru a evita sufocarea, țineți piesele mici departe de copii. Vă rugăm să păstrați manualul de instrucțiuni pentru referințe ulterioare. Vă rugăm să urmați instrucțiunile de asamblare pas cu pas și să identificați fiecare componentă după marca pe care o poartă înainte de a o utiliza. Nu trebuie depășită limita maximă de greutate pentru fiecare raft. Greutatea trebuie să fie distribuită uniform pe fiecare raft. Pentru o stabilitate maximă, asamblați dulapul fără picioare. Dulapul trebuie să fie fixat de un perete. Nu atârnați bunuri pe ușă și nu puneți obiecte pe marginea panoului superior. Accesoriile pentru fixarea dulapului pe perete nu sunt incluse.

FR

Armoire de service

Notice de montage: Pour éviter tout risque d'asphyxie, maintenez les petites pièces hors de portée des enfants. Veuillez conserver le manuel d'instructions en vue d'une utilisation ultérieure. Veuillez suivre les instructions de montage étape par étape et identifier chaque élément, grâce à la marque qu'il porte, avant de l'utiliser. La charge maximale pour chaque étagère ne doit pas être dépassée. Le poids doit être uniformément réparti sur chaque étagère. Pour un maximum de stabilité, monter le meuble sans les pieds. Le meuble doit être fixé au mur. Meuble à fixer au mur: Adapter votre quincaillerie en fonction du support. Veuillez ne pas suspendre d'articles sur la porte ou placer des objets sur le bord du panneau supérieur. Les accessoires pour un montage mural ne sont pas inclus.

EL

Ντουλάπα Αποθήκευσης

Οδηγίες Συναρμολόγησης: Κρατήστε τα μικρά μέρη μακριά από τα παιδιά για αποφυγή τυχόν ασφυξίας. Παρακαλούμε φυλάξτε το εγχειρίδιο για μελλοντική χρήση. Ακολουθήστε τις οδηγίες συναρμολόγησης βήμα-βήμα και αναγνωρίστε κάθε κομμάτι από τον κωδικό που φέρει πριν να το χρησιμοποιήσετε. Το βάρος πρέπει να καταμετράται ισομερώς σε κάθε ράφι & να μην υπερβαίνει το ανώτερο επιτρεπτό όριο βάρους ανά ράφι. Για μέγιστη σταθερότητα συναρμολογήστε την ντουλάπα χωρίς τα πόδια. Στερεώστε την ντουλάπα στον τοίχο. Αποφεύγετε την τοποθέτηση αντικειμένων στην πόρτα της ντουλάπας ή στην άκρη της οροφής της ντουλάπας. Αξεσουάρ για την σύνδεση στον τοίχο δεν περιλαμβάνονται σε αυτή την συσκευασία.

SL

Omare za shranjevanje

Navodila za sestavljanje: Da bi se izognili zadužitvi, hranite majhne dele stran od otrok. Priročnik z navodili shranite za poznejšo uporabo. Upoštevajte navodila za sestavljanje po korakih in pred uporabo prepoznajte vsak sestavni del po oznaki, ki jo ima. Največja dovoljena teža za vsako policjo ne sme biti presežena. Teža mora biti enakomerno razporejena na vsaki polici. Za največjo stabilnost omaro sestavite brez nog. Omarico je treba pritrditi na steno. Na vrata ne obešajte blaga in ne postavljajte predmetov na rob zgornje plošče. Dodatki za pritrditev omare na steno niso vključeni.

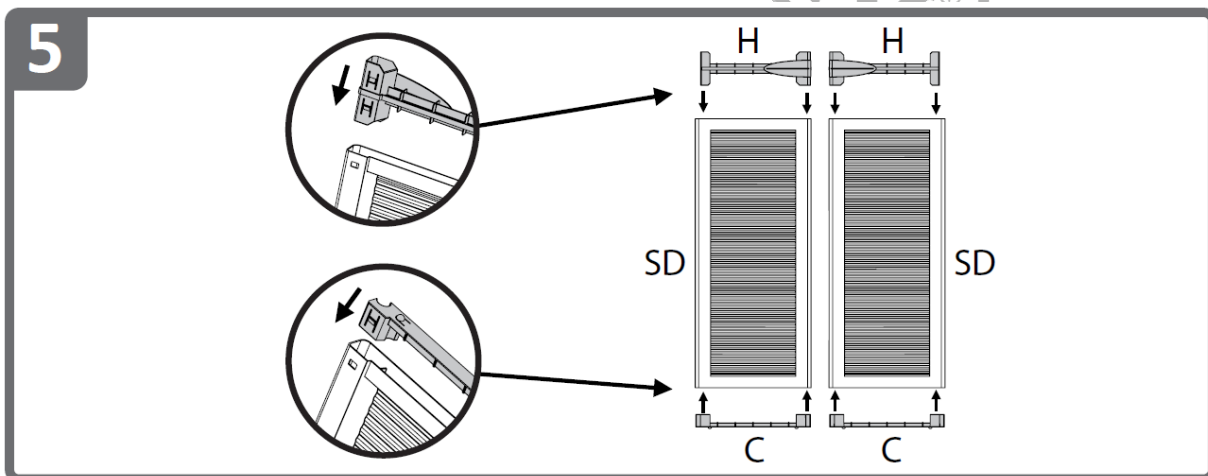
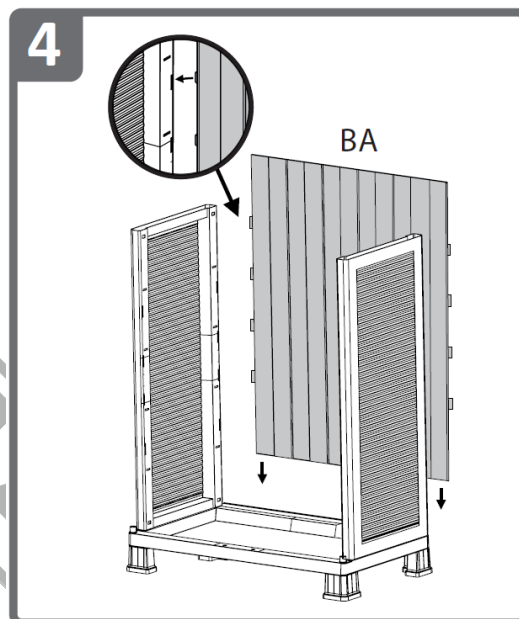
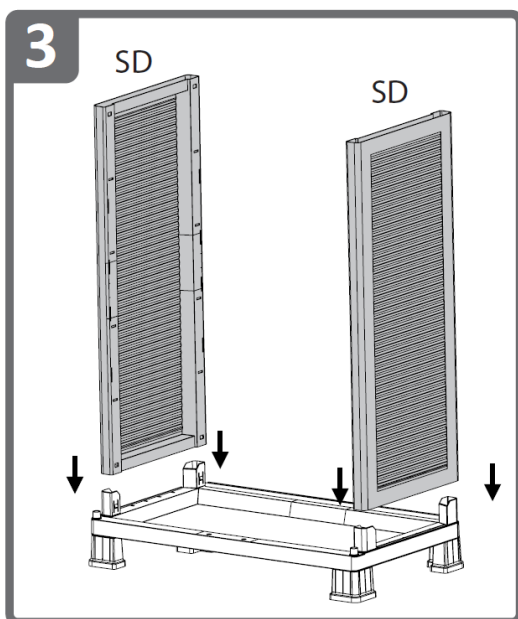
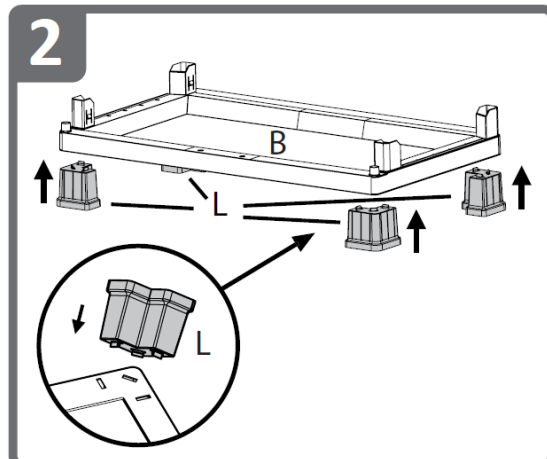
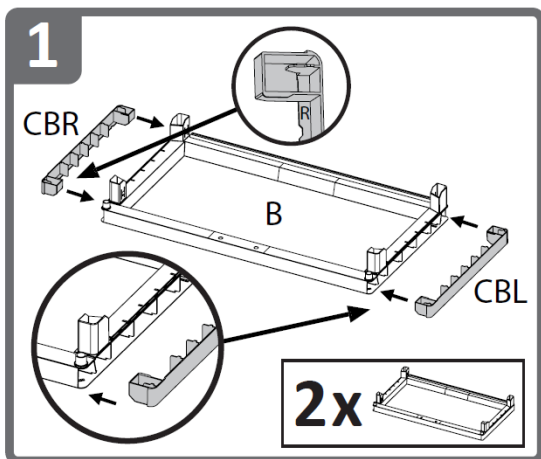

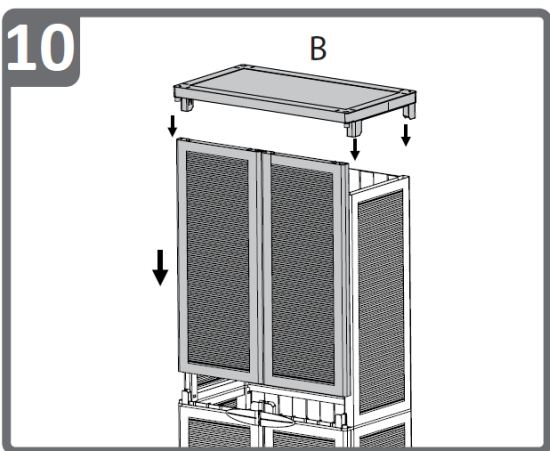
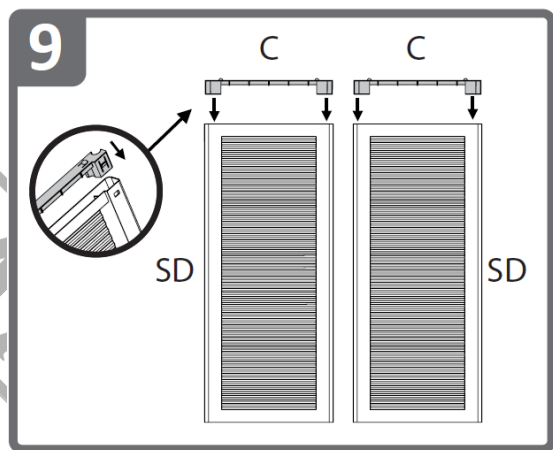
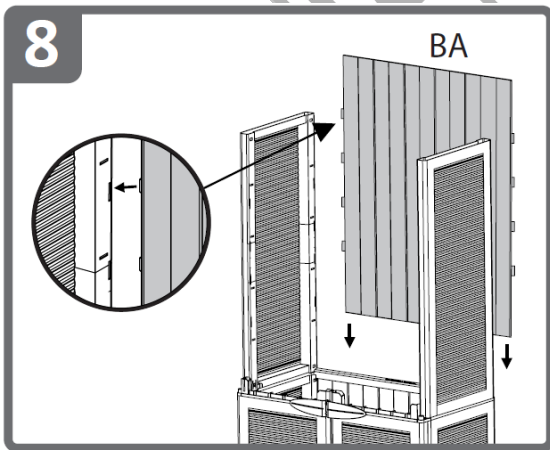
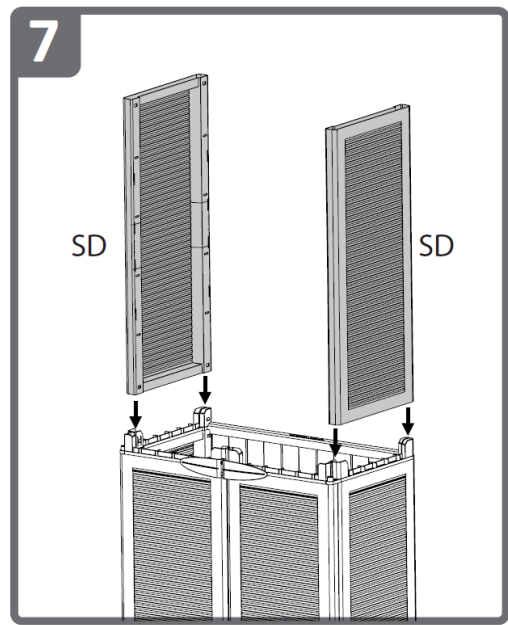
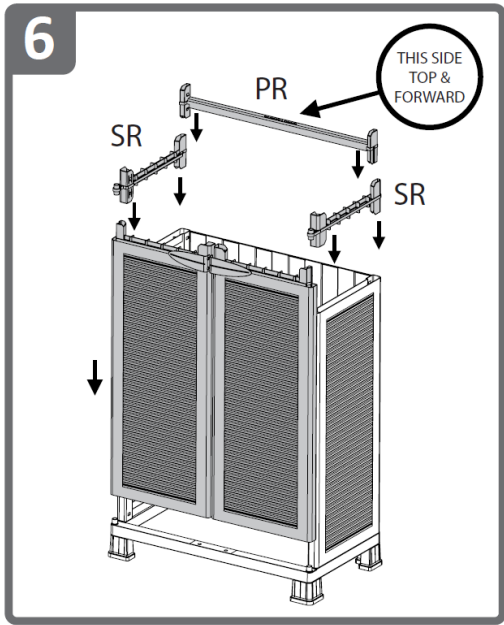

11

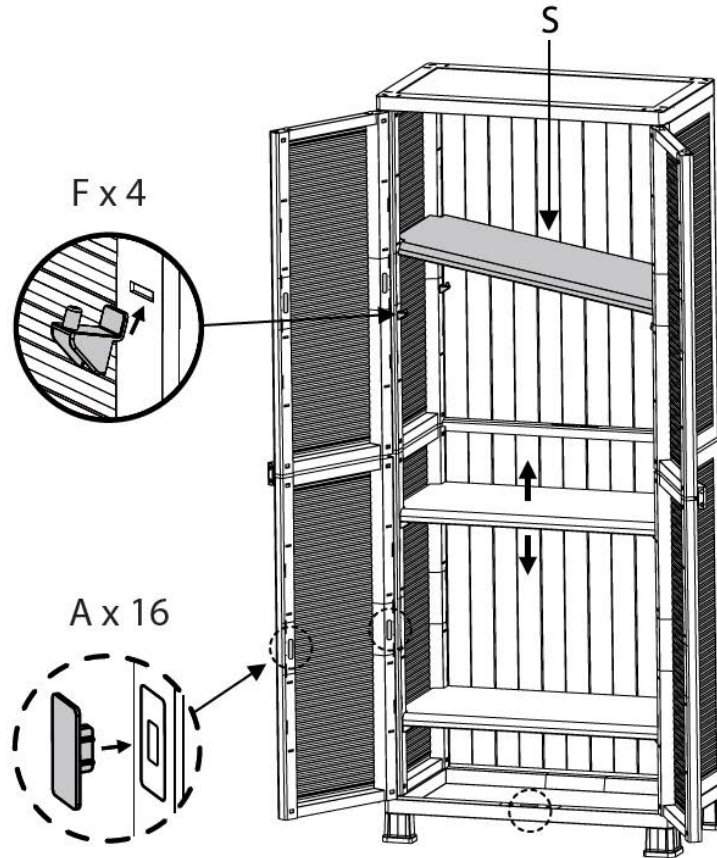

12



Accessories for attaching the cabinet to the wall are not included.

Les accessoires pour un montage mural ne sont pas inclus.

Gli accessori per il fissaggio al muro non sono inclusi.

Αξεσουάρ για την σύνδεση στον τοίχο δεν περιλαμβάνονται σε αυτή την συσκευασία.

Акcesoарите за закрепване на шкафа към стената не са включени.

Dodatki za pritrditev omarice na steno niso vključeni.

Accesoriiile pentru fixarea dulapului pe perete nu sunt incluse.

